

A POWER EFFICIENT SMART HELMET FOR SAFE DRIVING AND DROWSINESS DETECTION

An Undergraduate CAPSTONE Project

By

- | | | |
|------------------------------|----------------|-----------|
| 1. Aminul Islam | ID: 19-39571-1 | Dept: EEE |
| 2. Md.Nazmul Hossain | ID: 19-39651-1 | Dept: EEE |
| 3. Ibrahim Khandokar Tamim | ID: 19-40056-1 | Dept: EEE |
| 4. Md.Moshiour Rahman Shakil | ID: 19-39682-1 | Dept: EEE |

Under the Supervision of

Abir Ahmed

Assistant Professor

Fall Semester 2022-2023

January, 2023



Faculty of Engineering
American International University - Bangladesh

A POWER EFFICIENT SMART HELMET FOR SAFE DRIVING AND DROWSINESS DETECTION

A CAPSTONE Project submitted to the Faculty of Engineering, American International University - Bangladesh (AIUB) in partial fulfillment of the requirements for the degree of Bachelor of Science in their mentioned respective programs.

1. Aminul Islam	ID: 19-39571-1	Dept: EEE
2. Md.Nazmul Hossain	ID: 19-39651-1	Dept: EEE
3. Ibrahim Khandokar Tamim	ID: 19-40056-1	Dept: EEE
4. Md.Moshiour Rahman Shakil	ID: 19-39682-1	Dept: EEE

**Fall Semester 2022-2023,
January 2023**



**Faculty of Engineering
American International University - Bangladesh**

DECLARATION

This is to certify that this project is our original work. No part of this work has been submitted elsewhere partially or fully for the award of any other degree or diploma. Any material reproduced in this project has been properly acknowledged.

AIUB reserves the right to reuse/update any proprietary material designed and developed for this work.

Students' names & Signatures

1. Aminul Islam

Aminul

2. Md.Nazmul Hossain

Nazmul

3. Ibrahim Khandokar Tamim

Tamim

4. Md.Moshiour Rahman Shakil

Shakil

APPROVAL

The CAPSTONE Project titled **A POWER EFFICIENT SMART HELMET FOR SAFE DRIVING AND DROWSINESS DETECTION** has been submitted to the following respected members of the Board of Examiners of the Faculty of Engineering in partial fulfillment of the requirements for the degree of Bachelor of Science in the respective programs mentioned below on **January 2023** by the following students and has been accepted as satisfactory.

- | | | |
|------------------------------|----------------|-----------|
| 1. AMINUL ISLAM | ID: 19-39571-1 | Dept: EEE |
| 2. MD.NAZMUL HOSSAIN | ID: 19-39651-1 | Dept: EEE |
| 3. IBRAHIM KHANDOKAR TAMIM | ID: 19-40056-1 | Dept: EEE |
| 4. MD.MOSHIOUR RAHMAN SHAKIL | ID: 19-39682-1 | Dept: EEE |



Supervisor
Abir Ahmed
Assistant Professor
Faculty of Engineering
American International University-
Bangladesh



External Supervisor
Nuzat Nuary Alam
Assistant Professor
Faculty of Engineering
American International University-
Bangladesh

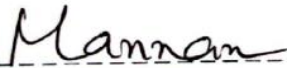

Prof. Dr. Md. Abdul Mannan
Director
Faculty of Engineering
American International University-
Bangladesh



Prof. Dr. ABM Siddique Hossain
Dean
Faculty of Engineering
American International University-
Bangladesh

ACKNOWLEDGEMENT

We are indebted to the Almighty for the blessings that enabled us to complete our thesis successfully. We'd like to thank our respected thesis supervisor, Abir Ahmed, Assistant Professor in the Department of Engineering at American International University–Bangladesh, for taking the lead in this area of study and providing us with invaluable advice, support, and encouragement throughout the process. Then, we owe a debt of gratitude to our external supervisor, Nuzat Nuary Alam, who provided us with encouragement and helpful suggestions as we worked to expand upon this thesis. Sincere appreciation for this thesis's approval goes out to Dr. Carmen Z. Lamagna, Vice Chancellor, and Prof. Dr. ABM Siddique Hossain, Dean, American International University–Bangladesh.

Thank you to everyone who has been so understanding and helpful throughout this time.

1. Aminul Islam
2. Md.Nazmul Hossain
3. Ibrahim Khandokar Tamim
4. Md.Moshiour Rahman Shakil

TABLE OF CONTENTS

DECLARATION	I
APPROVAL.....	II
ACKNOWLEDGEMENT	III
LIST OF FIGURES	VI
LIST OF TABLES.....	VIII
ABSTRACT	IX
CHAPTER 1	1
INTRODUCTION.....	1
1.1. Overture	1
1.2. Engineering Problem Statement	2
1.3. Related Research Works.....	2
Earlier Research.....	
Recent Research	4
1.4. Critical Engineering Specialist Knowledge.....	5
1.5. Stakeholders.....	5
1.6. Objective of this Work	6
Primary objectives	6
Secondary Objectives	6
1.7. Organization of Book Chapters	6
CHAPTER 2	7
PROJECT MANAGEMENT	7
2.1. Introduction	7
2.2. S.W.O.T. Analysis of the Project	7
2.3. Schedule Management.....	9
2.4. Cost Analysis	10
2.5. P.E.S.T. Analysis	10
2.6. Professional Responsibilities	12
2.6.1. Norms of Engineering Practice.....	13
2.6.2. Individual Responsibilities and Function as effective team member	13
2.7. Management principles and economic models.....	13
2.8. Summary.....	14
CHAPTER 3	15
METHODOLOGY AND MODELING	15
3.1. Introduction	15
3.2. Block Diagram and Working Principle	15
3.3. Modeling.....	17
3.4. Summary.....	19
CHAPTER 4	20

PROJECT IMPLEMENTATION	20
4.1. Introduction	20
4.2. Required Tools and Components	20
4.3. Implemented Models	23
4.3.1. Simulation Model	23
4.3.2. Hardware Model	24
4.4. Summary	25
CHAPTER 5	26
RESULTS ANALYSIS & CRITICAL DESIGN REVIEW	26
5.1. Introduction	26
5.2. Results Analysis	26
5.2.1. Simulated Results	27
5.2.2. Hardware Results	29
5.3. Comparison of Results	35
5.4. Summary	36
CHAPTER 6	37
CONCLUSION	37
6.1. Summary of Findings	37
6.2. Novelty of the work	37
6.3. Cultural and Societal Factors and Impacts	38
6.4. Engineering Solution in accordance with professional practices	25
6.5. Limitations of the Work	38
6.6. Future Scopes	38
6.7. Social, Economic, Cultural and Environmental Aspects	39
6.7.1. Sustainability	39
6.7.2. Economic and Cultural Factors	39
6.8. Conclusion	40
REFERENCES	41
APPENDIX A	44
CODE	46
APPENDIX B	58
DATASHEET OF THE ICs USED	56
APPENDIX C	59
SURVEY QUESTIONS	59
APPENDIX D	61
I ^T HENTICATE PLAGIARISM REPORT	61

LIST OF FIGURES

FIGURE 1.1	THE GAZE OF THE DRONE CAMERA CONTROLLED BY THE LEARN LEADER'S HELMET MOUNTED BOARD	3
FIGURE 2.1	S.W.O.T ANALYSIS.....	8
FIGURE 2.2	SCHEDULE MANAGEMENT.....	9
FIGURE 2.3	COST ANALYSIS.....	10
FIGURE 2.4	P.E.S.T ANALYSIS.....	11
FIGURE 3.1	BLOCK DIAGRAM OF THE PROJECT	15
FIGURE 3.1	BLOCK DIAGRAM OF THE PROJECT	15
FIGURE 3.2	3D MODEL FROM VARIOUS ANGLES.....	17
FIGURE 3.3	TRANSPARENT MODEL.....	18
FIGURE 4.1	LCD DISPLAY	19
FIGURE 4.2	SIM800L MINI GPRS GSM MODULE	20
FIGURE 4.3	ADXL335.....	21
FIGURE 4.4	U-BLOX NEO-6M GPS MODULE	22
FIGURE 4.5	PROTEUS MODEL.....	23
FIGURE 4.6	HARDWARE MODEL.....	23
FIGURE 5.1	SIMULATED BLOCK DIAGRAM	26
FIGURE 5.2	SIMULATED SYSTEM HAS STARTED	27
FIGURE 5.3	RIDER'S DROWSINESS HAS DETECTED.....	27

FIGURE 5.4	SENDING MESSAGE AFTER ACCIDENT DETECTION	28
FIGURE 5.5	FIGURE OF THE SMART HELMET.....	29
FIGURE 5.6	ACCIDENT DETECTED	30
FIGURE 5.7	FALSE ACCIDENT ALERT CANCELLED AFTER PRESSING THE PUSH BUTTON	30
FIGURE 5.8	SMS SENDING WITH LIVE GPS LOCATION	30
FIGURE 5.9	SMS FROM THE SMART HELMET.....	31
FIGURE 5.10	GPS LOCATION FROM THE SMART HELMET	31

LIST OF TABLES

TABLE 2.1	COST ANALYSIS	10
TABLE 2.2	INDIVIDUAL RESPONSIBILITIES AND FUNCTION AD EFFECTIVE TEAM MEMBER.....	13
TABLE 5.23	TABLE OF RESULT	33

ABSTRACT

A smart helmet is a form of protective headgear worn by the rider that contributes to a more secure experience while riding a motorcycle. This helmet's primary function is to protect the rider's head from injury. Use of advanced features such as drowsiness detection, accident identification, location monitoring, hands-free use, and fall detection can help achieve this goal. This creates a feature of a smart helmet. When the rider is wearing the helmet and if the rider fell drowsy, the helmet will detect the event by the IR sensor and will turn on the buzzer to alert the rider. In the event of an accident, the GSM module will transmit a message with the GPS location attached. The unique benefit of this project is its ability to recognize when a rider has fallen off the bike and deliver a notification.

Chapter 1

INTRODUCTION

1.1.Overture

When something happens that you didn't see coming or that you didn't plan for, we call that an accident. One of the most common causes of car crashes is driver's carelessness. The government has mandated that all motorcyclists must wear helmets and that drunken riding is prohibited. The cyclists continue to disregard the regulations. The riders' carelessness is at blame for these incidents. When riders don't wear helmets, they risk head trauma and perhaps death. An intelligent system, smart helmet, is presented as a solution; this system can detect both the accident and the tiredness condition of the rider [1]. The system consists of an accelerometer, GSM, GPS with the former installed in the rider's helmet. Several sensors check if the helmet is properly affixed to the head. When the likelihood of hit is greatest, these ADXL335 sensors are installed in the helmet to detect the accident. An IR sensor is positioned close to the rider's eyes. [2] The blink of the rider is analyzed by the IRsensor. This smart helmet can be an effective instrument for identifying and responding to accidents. It is equipped with GSM (Global System for Mobile Communications), GPS (Global Positioning System), and ADXL335 (accelerometer), GSM is a cellular technology used for speech and data transmission across long distances. In the case of an accident, this enables the helmet to connect to a cellular network and relay alerts to emergency personnel or predetermined contacts. GPS is a satellite-based navigation system that enables the helmet to detect its exact location. This can be beneficial for providing the accident's location to emergency personnel. Accelerometer is capable of measuring acceleration, tilt, and shock. This device can detect sudden changes in motion, such as those that occur during an accident, by being integrated into the helmet. When an accident is detected, the helmet can automatically send an SMS or call to emergency personnel with the user's details and the location of the accident. This can drastically cut response times and increase the likelihood of success. If any false vibration is detected, then the rider can stop message sending by pressing the push button. Additionally, GPS and GSM technology enable the helmet to continuously track the user's location, which is important in the event of an emergency where the individual is unable to communicate and the helmet can alert the individual's emergency contact.

Overall, the integration of GSM, GPS, and ADXL335 into a smart helmet can significantly improve the ability to detect and respond to incidents, which could save lives.

1.2.Engineering Problem Statement

A smart is a unique innovation that improves the safety of motorcycling. It's a way to prevent the engine from revving on a vehicle even if the driver is too drunk to operate the vehicle safely. Not only that, but it's got a great characteristic for detecting incidents and data RMS Special Effects Televised Imagery GPS coordinates and speeds at the time of the accident can be calculated using an SMS GPS GSM basic tracking system, using ambulance to reach the correct location. It's like to implement every sensor in the helmet, which will relay data to the bike's control module. This smart bike's alarm system will include two separate modules: one for the hub and one for the bike itself. If there is an accident count while wearing this helmet,the location message will be sent to the specific phone number through GPS. Moreover,the blink test can be determined by the IR sensor.

1.3.Related Research Works

Figure 1.1 suggests a new style of intelligent headgear. It can be mass-produced with little effort and can be made in enormous quantities. Carbon fiber will be used to create a sturdy exterior for it. To ensure that the wearer remains cool and comfortable, the helmet will include a towel. The design also includes vents with an easy-to-use mechanism for opening and closing them. The design also includes a headlight for use at night, turn signals, brake lights, and a global positioning system [3]. A Bluetooth device will be used for management. A portable audio player (with bone conduction headphones) can be used to listen to music or get directions. Power for the onboard electronics will come from a battery pack, the enclosure for which will be integrated into the main housing.

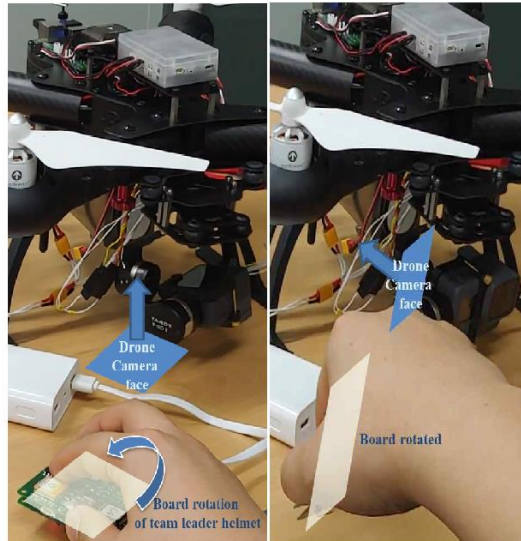

Figure 1.1: The gaze of the drone camera controlled by the team leader's helmet-mounted board [1]

The primary goal in writing this article was to design a safety system that would work in tandem with a smart helmet and an intelligent bike to lessen the likelihood of drunk driving and other incidents involving two-wheeled vehicles.[2] The helmet's flex sensor can tell if it's being worn. Breath alcohol sensors quantify the percentage of ethanol in the exhaled air of motorists. The bike won't start if the rider isn't wearing a helmet or if alcohol is detected in their breath. The helmet's flex sensor can tell if it's being worn. If the rider fell drowsiness then the helmet give an alert. Accidents are reported when the rider's helmet hits the ground, and its sensors detect the resulting motion and tilt. It notifies the rider's loved ones and emergency contact of the rider's precise location in case of an accident.

The suggest a new style of intelligent headgear. It can be mass-produced with little effort and can be made in enormous quantities. Carbon fiber will be used to create a sturdy exterior for it. To ensure that the wearer remains cool and comfortable, the helmet will include a towel. The design also includes vents with an easy-to-use mechanism for opening and closing them. The design also includes a headlight for use at night, turn signals, brake lights, and a global positioning system[3]. A Bluetooth device will be used for management. A portable audio player (with bone conduction headphones) can be used to listen to music or get directions. Power for the onboard electronics will come from a battery pack, the enclosure for which will be integrated into the main housing.

1.3.1. Recent Research

Any related research which are generally not more than 5 years or 2 years old can be considered recent work. A clear indication should be there how the recent research complement the proposed project methodology.

A motorcycle, often known as a motorbike or a two-wheeler, is a type of inexpensive motor vehicle. On the flip side, this is the riskiest car on the road. Drunk driving and excessive speeding are also major causes of accidents. Traveling in a safe and secure vehicle is a top priority for everyone. Safety on the roads and security while riding a motorcycle have become pressing concerns due to the increasing density of metropolitan areas and the prevalence of alternative modes of transportation such as motorcycles and scooters [3]. The number of accidents has increased, resulting in numerous injuries and fatalities. It's not always possible to pinpoint the exact site of an accident. If you want to protect your noggin from harm, you should wear a helmet. Indeed, the helmet helps the skull do its job of shielding the brain. Two-wheeler travel is now safer thanks to smart helmets that can pinpoint the locations of accidents. In this study, we propose a system that uses smart helmets to detect potential danger and keep riders safe. The system can be thought of as a trifecta: headgear circuit, car circuit, and mobile app. At initially, there were infrared (IR) and GPS built into the helmet circuit. A three-axis accelerometer, Bluetooth module, relay, and load sensor are all part of the car's circuit. If the helmet detects no drowsiness, the circuit will signal the car's circuit to commence. After that, the auto circuit verifies that the load is ready to go before turning on the ignition. 3-axis accelerometer senses crash or collision. After detecting an accident smartphone application communicates the accident location automatically to police and emergency contact number via the database.

There are millions of individuals who ride motorcycles and scooters, and many of them don't think it's important to wear a helmet. The focus of this study is on improving helmet design to make them more user-friendly and appealing.[5] The goal of this project is to provide a network connection for a motorcycle helmet, allowing it to provide cooling features, an internal display screen, and an alcohol sensor for the rider. These additions would turn the helmet into a "smart" one, increasing the rider's convenience and security.

A rising trend of mishaps involving online motorbike cab drivers. Since drivers take many different routes, it's hard to keep track of where accidents happen. The goal of this study is to develop a device that can be attached to the helmet of an online motorcycle taxi driver and used to monitor the driver's location. This study's methodology included having participants use the tool's built-in MLX90614 thermometer to

measure their core body temperature and using a helmet drop as a proxy for a head-on collision. This research makes use of the MLX90614 sensor, which displays passenger body temperatures on an OLED screen. Using the helmet's FSR402 sensor, which can detect impacts, this telegraph bot may relay the location of the mishap to the wearer. To find its precise location with the help of an Ublox Neo 6m GPS receiver [6]. The MLX90614 sensor, when used with an item 5 cm from the sensor, returns findings with a 95% confidence interval. The FSR402 sensor registers a value of 1024 just before an impact. Longitude and latitude measurements from an Ublox Neo 6m GPS sensor are accurate to within 99%.

1.4.Critical Engineering Specialist Knowledge

The purpose of this project is to create a smart helmet that can prevent accidents for bikers, particularly drowsy ones. In order to complete this project successfully, you will need to be well-versed in engineering and confident in your ability to deal with unexpected challenges. To maximize the project's usefulness to its target audience, it will incorporate a number of different features. A ADXL335 module will be implemented. It relies on capacitive principles to function. A change in capacitance occurs within the sensor as acceleration is applied. The acceleration of the object can be calculated from the resulting change in capacitance. After a collision, the GPS sensor can also be utilized to pinpoint your precise location. As part of this project, we integrated an infrared (IR) sensor to track the rider's eye blink rate. Transmission of data via mobile networks will be accomplished with the help of GPRS. Understanding this sensor and how it operates in depth is necessary. A familiarity with ARDUINO NANO will also be helpful. As the brains of this operation, an ARDUINO NANO will be used. This project's simulations will be run entirely in the Proteus Design Suite. To round up the process, it will check various output data using software simulation of the project's hardware circuit. The success of this project depends on the team's familiarity with the necessary hardware and software to complete it as planned.

1.5.Stakeholders

The transportation industry is one of our primary targets for the development of our smart helmet. The number of people using motorcycles grew steadily over the course of a week. Two-wheeled vehicles are more prone to random mishaps. For this reason, it is likely that all bicycles will eventually adopt this form of intelligent headgear.

1.6.Objectives

1.6.1. Primary Objectives

- Low-cost approach of implementing a smart Bluetooth motorcycle helmet.
- Allow the user of the helmet to accept phone calls, stream music, and be able to utilize GPS through an app.
- Energy absorption from the solar panel.

1.6.2. Secondary Objectives

- Light weight
- Good visibility
- Consistent with dismounted activities

1.7.Organization of Book Chapters

Chapter-2: Project Management

In this Chapter, the project Gantt chart has designed in this project management chapter. Then, analysis the different related issues as such strength of this project, weakness and opportunities.

Chapter-3: Methodology and Modeling

In this methodology chapter, the proposed designed with block diagram also mathematically

Chapter-4: Implementation of Project

In this the modified chapter, the proposed model will be described

Chapter-5: Results Analysis & Critical Design Review

All the graphs and project analysis will be shown

Chapter-6: Conclusion

Chapter 2

PROJECT MANAGEMENT

2.1.Introduction

Project management is a common method used to assure the success of a project. When it comes to project management, it's critical to have a clear picture of the objectives of the project, the resources this project needs, and achieve it. This chapter is all about getting down to business. The purpose of project management is to plan and execute a project in such a way that its stated goals and deliverables are met. Additionally, it includes the identification and control of potential risks, along with a thorough budgeting process and cross-organizational communication [7]. Project schedules can benefit from using the Gantt chart. Money can be saved on the project's equipment by manipulating the data. Managing a project is a critical managerial ability. Planning, scheduling, and regulating actions to achieve a certain goal within a given time and budget are all part of the process. By completing initiatives that contribute to project aims, many businesses can meet the objectives. In most cases, projects have a specific start and end date, a specific number of participants, a specific number of resources, and a specific budget. This is planned and monitored by the group leader and adjusted just as needed.

2.2.S.W.O.T. Analysis

S.W.O.T Analysis is shown in figure 2.1. A project's opportunities and threats, as well as its strengths and weaknesses, can be analyzed using the SWOT framework. Using a functional approach, the internal analysis pinpoints the projects' strengths across the board (finance, management, infrastructure, procurement, production, distribution, marketing, reputational factors, and innovation) as well as its weaknesses (the same) and opportunities for growth (the same). Finding the source of competitive advantage requires a thorough internal study. In doing so, it identifies areas for investment in developing resources that will keep a team motivated. Potential advantages and disadvantages in the sector are uncovered through research on the surrounding environment, including the competition, the industry, and the broader economy. Analysis of the capabilities and assets of each competitor constitutes the competitive landscape. Competition, new entrants, suppliers, customers, and product substitution are

analyzed as part of the industry's external environment using the five Forces Model. Political, economic, sociological, technological, environmental, demographic, ethical, and regulatory repercussions are examined in the context of the external environment.[8] The objective of doing a Strengths, Weaknesses, Opportunities, and Threats (SWOT) study is to inform a company's strategy development considering its specific context. In this using SWOT analysis, the strength and weaknesses are found.



Figure 2.1 S.W.O.T Analysis[28]

2.2.1. Strengths

- Solar Charges green energy which allows the helmet to be recharged all the time.
- Light weight and portable
- Boost productivity, efficiency and effectiveness.
- The cost will be low compared to the price of smart helmets exist in market.

2.2.2. Weaknesses

- Wi-Fi delay
- Sometimes disconnections an happen on the internet

Opportunities

- Property ownership grants from the government
- Iot Job opportunities in the helmet sector

2.2.3. Threats

- Ineffectual delivery of alert, straining the competent working of the helmet.
- Increased time for information transfer and incident resolution

2.3. Schedule Management

Schedule management has been given in figure 2.2. Project activities and tasks are organized using a schedule management structure, which uses time variables to do so. Outlines what has to be done for the project's completion to be on time and within the budget. Implementing a schedule management system is crucial to getting a project off the ground, tracking its progress, and ensuring that it is completed on time.

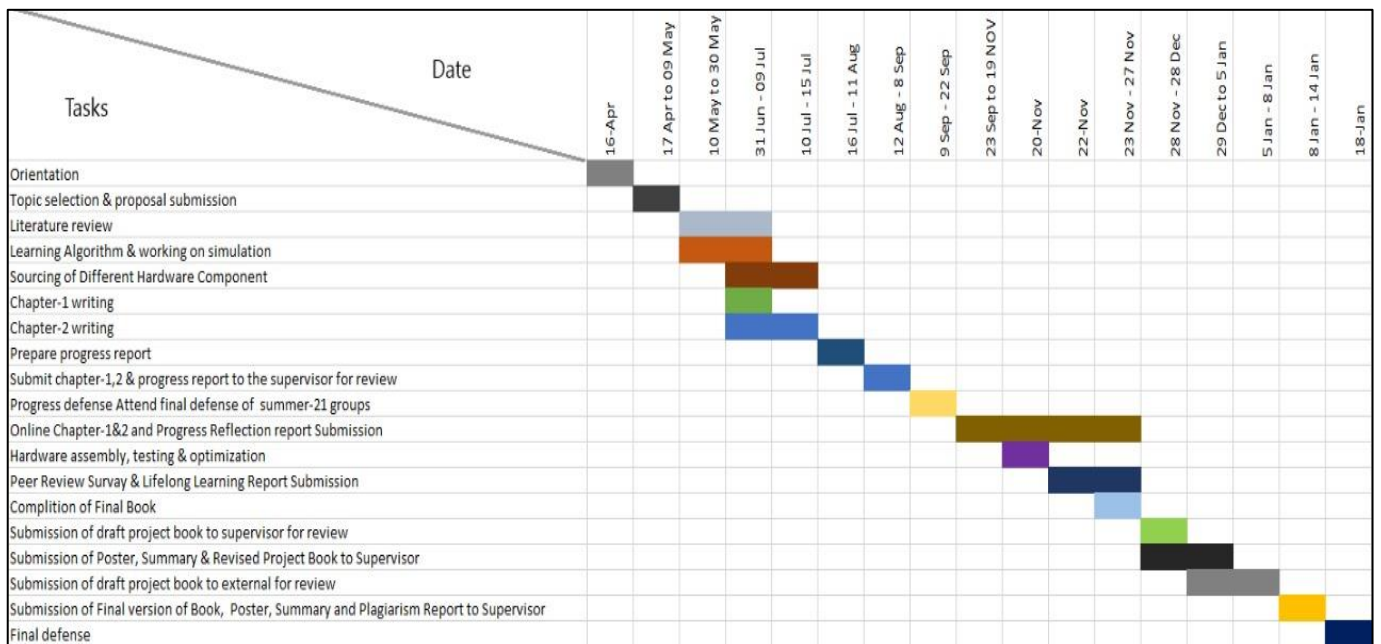

Figure 2.2 Gantt Chart

2.4. Cost Analysis

Cost analysis of this project is shown in figure 2.3

SL.	Equipment	Quantity	Cost
1	I2C LCD Display (16x2)	1	240/-
2	SIM800L Mini GPRS GSM Module	1	450/-
3	ADXL335 Module 3-axis Analog Output	1	445/-
4	Accelerometer GY-61	1	450/-
5	u-blox neo-6m gps module	1	606/-
6	Arduino Nano	1	850/-
7	Mini Power Solar Cells Panel 3.7V 40X30mm	3	400/-
8	lm2596 buck converter	1	180/-
9	xl6009 dc-dc booster	1	130/-
10	Push button	1	5/-
11	Battery 3.7v	1	90/-
12	Helmet	1	1000/-
Total=			5646/-

Figure 2.3: Cost Analysis

Now according to the standard deviation formula equation,

For standard deviation calculation,

N=14

Sum, ΣX : Online price (BDT) + Final expenditure price (BDT)

$$= 14835$$

Mean, μ : Sum /N

$$= \frac{5646}{12}$$

$$\text{Variance} = \sigma^2 = \frac{1}{N} \sum (x_i - \mu)^2 = \frac{5646}{12-1}$$

$$\text{Standard deviation} = \sqrt{\text{Variance}} = \sqrt{513.27} = 22.65$$

2.5.P.E.S.T. Analysis

Figure 2.4 shows the arrangement of P.E.S.T analysis. To assess a project's current situation, future prospects, and strategic course of action, the PEST analysis is an invaluable tool. [13] Businesses and other organizations often do market analyses by considering political, economic, social, and technological (PEST) issues. A PESTLE analysis considers other aspects, such as those related to the law and the environment.



Figure 2.4: P.E.S.T analysis

2.5.1. Political Analysis

The analysis of political structures, institutions, ideas, and behaviors, and most importantly, the political processes through which they are constantly formed and changed, is made accessible and engaging in Political Analysis. This project won't require approval from the government to carry out its initiative. This project can be implemented without any restrictions.

2.5.2. Economic Analysis

Cost-benefit analysis is the core of the economic analysis. First, it uses economic viability to rate projects, so that funds can be distributed more efficiently. The purpose of this study is to evaluate a project's contribution to society. It is reasonable and cost-effective, and this project's initiative is to be accessible to everyone. The researchers need to keep the budget in mind throughout the implementation process.

2.5.3. Social Analysis

Analyzing stakeholder perspectives and priorities, and involving as many relevant stakeholders as possible in the development process, are all components of social analysis. This analysis is conducted in the context of the socio-cultural, institutional, historical, and political environment of Bank-financed operations. It's a team project and its target market may be affected by certain societal trends, behaviors, or attitudes

2.5.4. Technological Analysis

Dynamic vehicle has been featured in cars for aiding driver awareness of their surroundings and providing warnings to take preventative action in the event of a collision. Recently, technology has advanced to the point where it can act on behalf of a driver to avoid potentially disastrous situations including head-on crashes, backing into obstacles or traffic, or veering out of a delineated lane. The decisions made when driving, riding, and walking have a direct impact on public safety. However, modern automobiles can assist. Automobile safety is nowadays a great concern. So, the app-based authentication system now applies to most the smart vehicles to provide security.

2.6. Professional Responsibilities

The job of an engineer is to make sure that a system, method, or product is safe and effective. To make project a success, engineers must work well in groups and be able to work well with others. Engineers, customers, and businesses need to communicate effectively. Engineers are also responsible for the following:

- Using comprehensive drawings to draw out plans
- Preparing estimates and budgets for projects
- Defining the scope of the project

- Designing experiments in the field of engineering
- Producing customer-facing technical reports
- Completing safety-related regulatory documents
- On-time and within-budget completion of projects
- Informing clients and co-workers of findings and conclusions from the analysis

2.6.1. Norms of Engineering Practice

A "norm" refers to a set of moral rules or standards. To strike a balance between technological and ethical possibilities, normative design should be used while making trade-offs in design. Creating in this manner Engineers are obligated by law to undertake impact assessments to guarantee that designs have a favorable effect on society. As a business owner, it's critical to make sure that staffs feel appreciated. To accomplish the tasks effectively, engineering managers must prioritize the development of the staff's talents. The manager needs to have a clear growth plan and open communication with staff about the abilities, needs, improvements, and aspirations.

2.6.2. Individual Responsibilities and Function as Effective Team Member

Name	ID No	Responsibility
Aminul Islam	19-39571-1	Project lead
Md.Nazmul Hossain	19-39651-1	Hardware lead
Md. Moshior Rahman Shakil	19-39682-1	Software lead
Ibrahim Khandokar Tamim	19-40056-1	3D Modeling

2.7. Management Principles and Economic Models

We should rejoice in the many ways in which scientific and technological advancements have improved people's lives. All these innovative breakthroughs were produced for the sake of humanity. The project's hardware architecture will make use of a variety of sensors and a microprocessor. Traditional management practices and economic models provide a significant challenge to the Smart Helmet's development. We need to be careful with our spending on materials and labor because we are footing the

cost for the whole job ourselves. Spending a lot of money on labor and materials to complete a job of this size is to be expected. Used microcontrollers and other electronic parts allowed us to save money. The final design's development, production, and testing will be slowed not only by financial, but also by time constraints. We shall keep in mind that we have only two semesters to go from concept to prototype. As much as we wished, we had to cut several planned enhancements to the Smart Helmet in order to stay on track for its initial release. It required some time to put the plan into action and to learn as much as possible about the technologies we were going to use and to find entirely new ones that would provide us with the abilities we sought.

2.8.Summary

Discussed in this section are the project's objectives, budget, task management, and SWOT analysis, as well as any potential dangers or advantages. Researchers can have faith in their decision to carry forward with the study because of what they have learnt from past initiatives and expense estimations. Due to the specified stakeholders, many more people will be able to take use of a wide variety of new possibilities.

Chapter 3

METHODOLOGY AND MODELING

3.1.Introduction

The smart accident detection helmet model utilizes a combination of sensors and technologies to give a comprehensive solution for accident detection and sleepiness prevention. The ADXL335 Module 3-axis Accelerometer is used to detect any abrupt or excessive vibrations that may suggest an accident, and the Arduino Nano microcontroller is used to establish the threshold level for vibration detection. If an accident is detected, the helmet sends a text message to a pre-programmed emergency contact number along with the wearer's GPS location so that relatives or friends can render assistance. The eye-directed IR sensor is used to detect tiredness, and if drowsiness is identified, a text message alarm is delivered to a predetermined contact number. On top of the helmet are small solar panels that are used to charge the battery and power the intelligent helmet.

3.2.Block Diagram and Working Principle

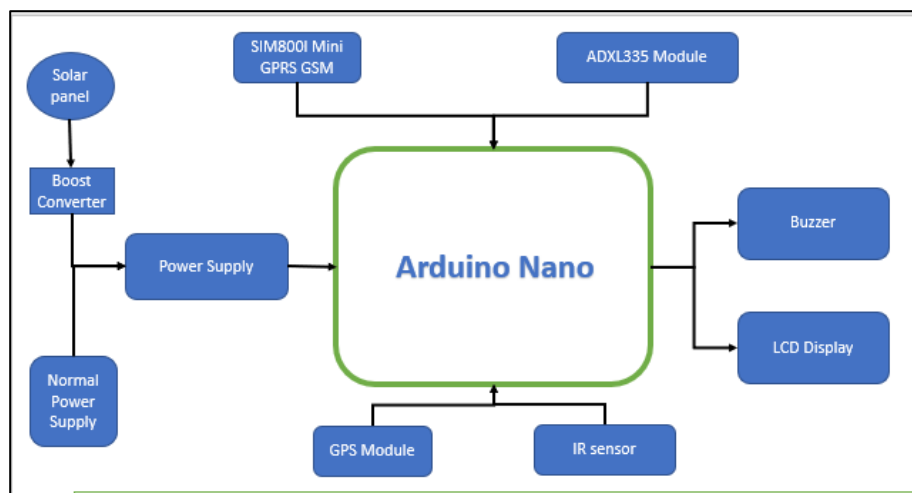

Figure 3.1: Block Diagram of the project

In figure 3.1 we show the block diagram of this project. The ADXL335 is a tiny, low-power, 3-axis accelerometer that measures acceleration along the x, y, and z axes. It is also frequently employed in the automotive, industrial, and medical industries. The ADXL335 accelerometer is a cost-effective and dependable solution for measuring acceleration in a variety of applications. Accidents and delayed

medical care are a third major problem. One of the leading causes of death after a motorcycle accident is the delay in receiving medical attention. People are dying every second because of long wait times for medical treatment or because the scene of an accident is unattended. The smart helmet is equipped with the accelerometer for use in the detection of falls. This system can detect potential accidents. The helmet has the following components: ADXL-335 Accelerometer, Buzzer, SIM800L GSM Module, GPS Module, IR sensor, LCD display, power supply. 5v mini solar panel, ignition system, and power supply unit. The Arduino Nano device controls the entire system. Sensors are used to regulate many processes. The Arduino Nano is installed in the headgear module. Different sensors send data to an Arduino unit, which processes the data and sends the accident alert. The SIM800L is a compact and inexpensive GSM/GPRS module that enables communication over a GSM or GPRS network. It has a variety of uses, including M2M communication, vehicle tracking, and monitoring systems. The SIM800L supports Quad-band 850/900/1800/1900MHz and can transmit Voice, SMS, and data while consuming little power. It also has a TCP/IP protocol stack, which facilitates integration with existing networks and systems. In conjunction with a buck converter, the SIM800L can function with a wide variety of input voltages, typically between 3.4V and 4.4V. The buck converter reduces the voltage to an appropriate level for the SIM800L module. This is essential for battery-powered applications in which the voltage level may vary. A buck converter guarantees that the SIM800L module receives a stable voltage level, hence enhancing communication stability and extending battery life. The GPS module is an accessory that enables the SIM800L to receive location data from a GPS satellite. This enables the module to establish its location and communicate that data to the system to which it is linked. This capability is applicable to a variety of applications, including car monitoring, personal tracking, and navigation. Additionally, accurate, the GPS module supports the NMEA 0183 protocol for GPS data. The SIM800L GSM/GPRS module with buck converter and GPS add-on is a cost-effective and dependable option for applications requiring both cellular and location data. The module is compact, simple to incorporate, and provides a solid solution for communication and position tracking even when the power source is unstable. The buck converter guarantees that the module receives a consistent voltage level, which enhances communication stability and extends battery life. Mini 5V solar panels are little, lightweight panels designed to convert sunshine into electricity. These solar panels are ideal for powering portable electrical gadgets including cellphones, tablets, and portable chargers. Additionally, they are perfect for usage in isolated regions when grid power is unavailable. Typically, the solar panel consists of photovoltaic cells that convert sunlight to direct current (DC) power. However, solar panels may not always produce sufficient electricity to power modern gadgets. Herein lies the function of the boost converter. A boost converter is an electronic circuit that raises the solar panel's output voltage, allowing it to power electronic devices. The boost converter functions by transforming the

solar panel's low voltage DC output into a higher voltage DC output. This is accomplished by employing a switching circuit that rapidly swaps a capacitor, hence increasing the voltage. Additionally, the boost converter regulates the device's voltage and current to guarantee a consistent power supply. In conclusion, a compact 5V solar panel with a boost converter is an excellent choice for powering small electronic equipment in isolated regions or as an emergency source of energy. The solar panel transforms sunlight into energy, while the boost converter raises the voltage to a level acceptable for electronic devices, assuring a stable power supply. In addition to being lightweight, portable, and simple to install, this package is ideal for a wide range of applications. IR sensor has been used to detect the driver drowsiness.

3.3. Modeling

The 3D design was made using fusion 360 software. In this design, the prototype and the transparency design of the prototype has been shown along with all the used components of the real life equipments. Solar panel, LCD, Battery cell were also designed to illustrate the whole theme of the project. Various angles of the project match with the real life implementation which has been done lately. Figure 3.2 shows the 3D model of various angles of the helmet 3D Model of various Angles (front view[a], left view[b], right view[c] , top view[d]). In first picture we see the front portion of the helmet[a], second picture shows the left portion of the helmet[b]. Third picture shows the right portion of helmet. we also see the solar panel and display in this[c]. Top view is shown in the last picture[d].

In figure 3.4 we see the transparent view of the helmet. Here we see the solar panel, battery, IR sensor, display.

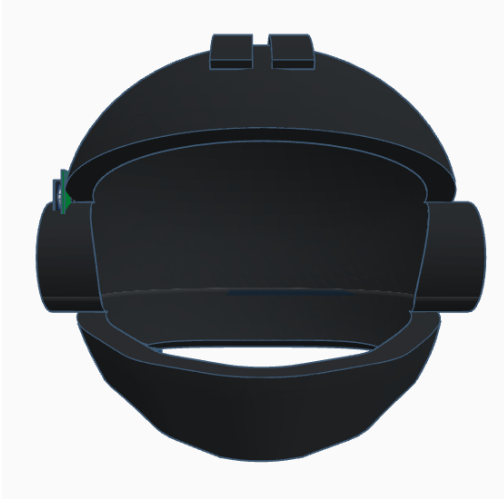

a

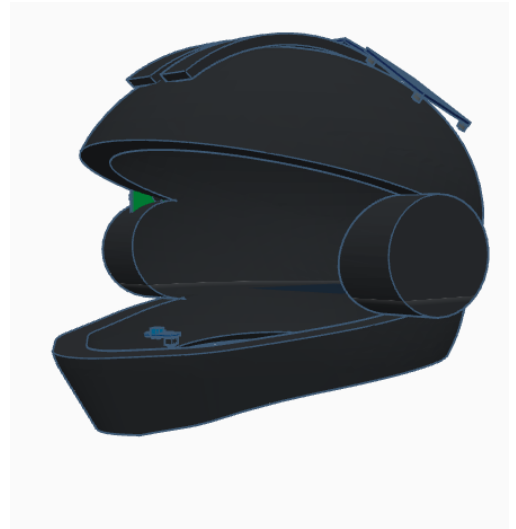

b

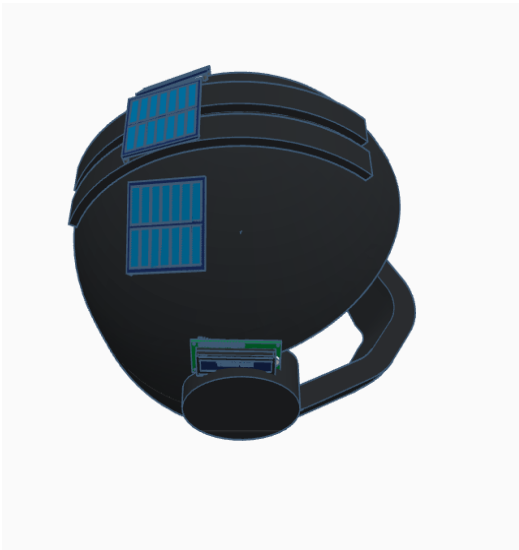

c



d

Figure 3.2: 3D Model of various Angles (a) Front view
(b) Left view (c) Right view (d) Top view

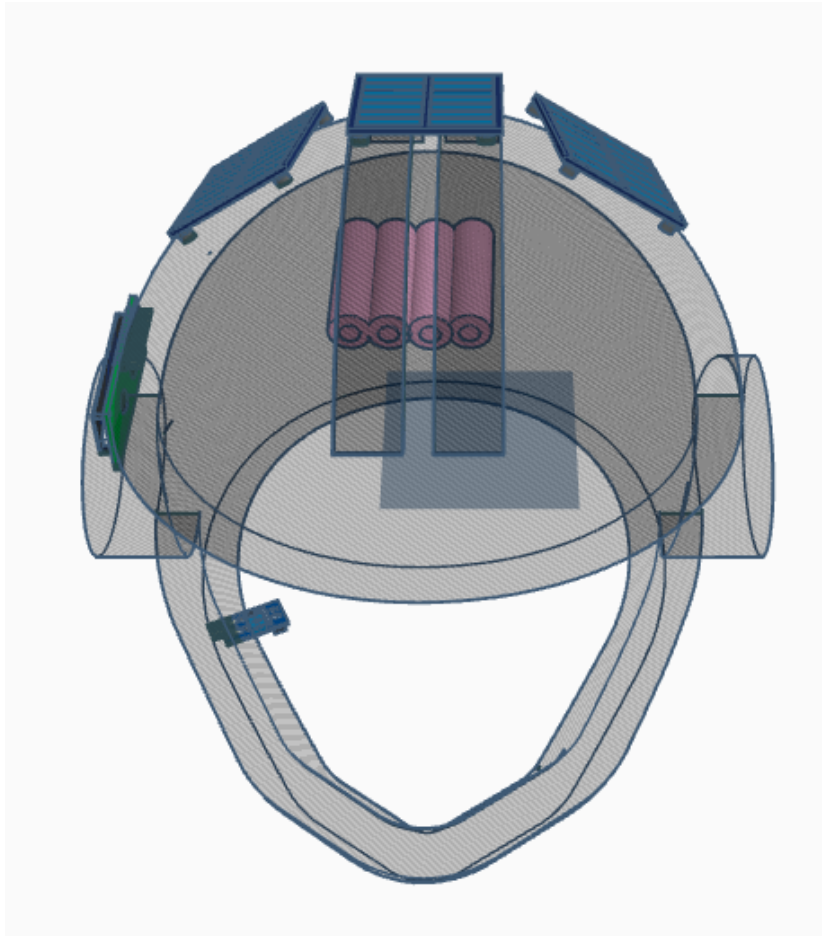

Figure 3.4: Transparent model to see the inner layer of the helmet

3.4.Summary

During any incident, there is no one around to help if an accident occurs, which contributes to the rising mortality toll. As these sorts of smart helmets become more commonplace, they will help prevent future accidents by alerting nearby medical facilities and allowing for prompt intervention in the event of an incident. These high-tech helmets are affordable enough for people of all socioeconomic backgrounds to utilize.

Chapter 4

PROJECT IMPLEMENTATION

4.1.Introduction

If a motorcyclist is involved in a high-velocity accident without a helmet, the impact can be lethal. A helmet's ability to dampen the effects of a collision could be the difference between life and death. Motorcycle riders in several countries, including Malaysia, are required by law to wear protective headgear while on the road. A smart helmet is a novel invention that will reduce motorcycle accidents. Both GSM and GPS technology are utilized to make this a reality. This smart helmet's operation is straightforward: it uses vibration sensors coupled to a microcontroller board to detect when the wearer is likely to be struck. Therefore, these sensors detect and provide to the microcontroller board, where the controller extracts GPS data using the GPS module interfaced to it when the rider crashes and the helmet hits the ground. The GSM module will automatically contact emergency services or loved ones if the data collected shows that the user's stress levels have increased over a predetermined threshold. In addition, it contains an alcohol detecting sensor that can shut off the car's power supply if the driver is too inebriated to operate the vehicle safely.

4.2.Required Tools and Components

4.2.1. I2C LCD Adapter Module



Figure 4.1: LCD display [23]

It's another high-quality blue/yellow backlit LCD screen. Due to Arduino's restricted pin resources, a standard LCD shield may not be used if a sufficient number of sensors or an SD card have been added to the board. With this I2C interface LCD module, though, you'll be able to achieve data display with just a pair of cables instead. There is no additional expense for this LCD module if you are currently using I2C devices in your project. It works wonderfully for any Arduino-based creation. Compatible with any 16x2 or 20x4 Character Display Module that operates in 4-bit mode, this I2C Serial LCD Daughter board complies with RoHS standards. [23] Our 162- and 204-line character modules, as well as the vast majority of commercially available character modules, all support 4-bit mode. The LCD display on this board receives its input through an I2C serial port, and this signal is converted to a parallel format by the PCF8574 I2C processor. Many online resources provide examples on how to use this board with Arduino. Look up "Arduino LCD PCF8574" online. While the board ships with the I2C address set to 0x3F, it can be altered using the three solder jumpers provided. To do this, up to three LCD screens can be assigned unique addresses on the same I2C bus.

4.2.2. SIM800L Mini GPRS GSM Module

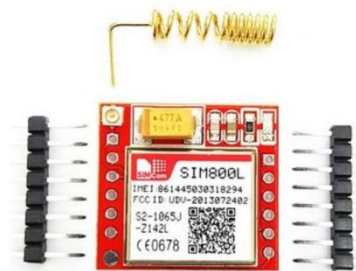

Figure 4.2: SIM800L Mini GPRS GSM Module [24]

This is the dual-antenna version of the tiny SIM800L GPRS GSM Module Micro SIM Card Core Board Quad-band TTL Serial Port. A SIM800L GSM/GPRS module is a small GSM modem that can be used in a wide variety of IoT applications. [24] This module allows you to send and receive SMS text messages, make and receive phone calls, connect to the internet via GPRS and TCP/IP, and much more, just like a regular cell phone. In addition, the module is compatible with the global quad-band GSM/GPRS network.

The first is a wire that solders directly to a PCB's NET pin, making it ideal for tight quarters. A second PCB antenna is joined to a pigtail cable through an IPX connector and held in place using double-sided tape. This one performs better and lets you house your module inside a metal enclosure, provided that the antenna remains exposed to the outside world.

4.2.3. ADXL335 Module 3-axis Analog Output Accelerometer GY-61

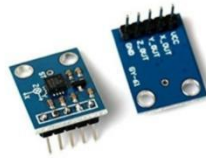

Figure 4.3: ADXL335 [25]

The ADXL335 is a complete three-axis accelerometer with signal-conditioned voltage outputs that is tiny, thin, and low-power. The minimum full-scale range of the ADXL335 Module 3-axis Analog Output Accelerometer is 3g. [25] Dynamic acceleration due to motion, shock, or vibration can be measured in addition to the static acceleration of gravity in tilt-sensing applications. This breakout board features a built-in voltage regulator that allows it to operate from 3.3V to 5V. (3-5V). One instrument that may measure acceleration forces is an accelerometer, which is an electromechanical device. Both static forces, like gravity's constant pull on your feet, and dynamic forces, created by the accelerometer's movement or vibration, are possible.

4.2.4. U-Blox NEO-6M GPS Module



Figure 4.4: U-Blox NEO-6M GPS Module [26]

This GPS Module is essential if you want to fly a drone long distances without having to manually map each new area. Drones that use global positioning system (GPS) technology can pinpoint their exact location on Earth thanks to a constellation of satellites in orbit above. Position hold, autonomous flight, return to home, and waypoint navigation are just some of the capabilities made possible by the drone's ability to connect to signals from these satellites. [26] This is an all-inclusive GPS unit that uses the NEO 6M satellite location system. This device has a larger built-in 25 x 25mm active GPS antenna with a UART TTL connection, and it uses cutting-edge technology to provide accurate positional data. To help you get a GPS lock more quickly, we've included a battery. The ardupilot mega v2 is compatible with this modernized GPS module. If you're using Ardupilot or another Multicopter control platform, this GPS module will provide you with the most accurate position data imaginable. The GPS module includes four pins labeled TX, RX, VCC, and GND for its serial TTL output. The u-center software allows for extensive customization of the GPS system via a computer. That program is top-notch; I highly recommend it.

4.3. Implemented Models

4.3.1. Simulation Model

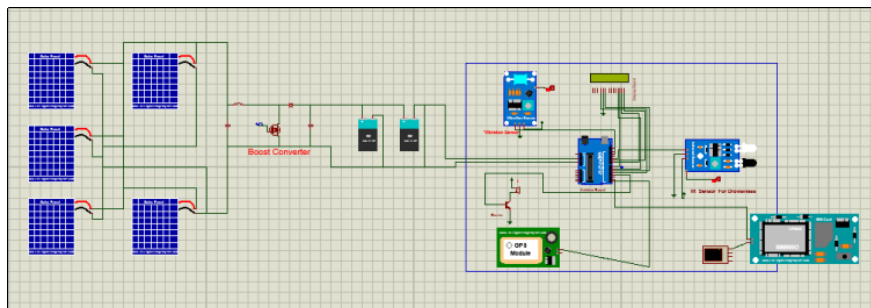

Figure 4.5: Proteus Model

A smart helmet is a type of headgear that includes innovative technologies to improve the wearer's safety and functionality. One such design, designed using the simulation software Porteous, includes a number of features that make it a cutting-edge option for motorcyclists and other folks who wear helmets often. It is a very useful simulation tool to design various project. Porteous simulation software significantly improves the design of solar panels. So solar penal part is also designed on the simulation. The simulated outcomes of this smart accident detection helmet project illustrate its efficacy in offering safety features for the wearer. The output of the ADXL335 Module 3-axis Accelerometer is connected to the Arduino Nano microcontroller in order to detect abrupt motion changes that may indicate an accident. The microcontroller is responsible for monitoring the sensor's output, determining if an accident has occurred, and sending a message to a pre-configured contact number with GPS coordinates, via the integrated GSM module, to notify the person's family or emergency contact of the accident and location. This helmet includes an IR sensor pointing at the wearer's eye to detect tiredness as an added safety feature. The IR sensor is attached to the Arduino Uno, and if drowsiness is detected, a warning message is delivered to the predetermined contact number. This function has the potential to prevent accidents resulting from driver fatigue. A collection of small solar modules put on top of the helmet provide electricity to the helmet, removing the need for regular charging. The user receives feedback from an LCD display board connected to the Arduino Nano, and an inbuilt buzzer connected to an NPN transistor and the Arduino Nano offers an auditory warning of danger.

4.3.2. Hardware Model



Figure 4.6: Hardware Model

The practical model of this smart accident detection helmet study provide insight into the design's effectiveness and dependability. The ADXL335 Module 3-axis Accelerometer was evaluated for its accuracy in detecting motion changes that may indicate an accident. The results demonstrate that the

sensor can detect rapid motion changes and deliver consistent output to the Arduino Nano microcontroller, which is responsible for assessing if an accident has happened. The ability of the IR sensor to detect tiredness was also investigated. The results demonstrate that the sensor can accurately detect drowsiness and deliver consistent output to the Arduino Nano microcontroller, which triggers a message to be sent to a preconfigured contact number informing them of the wearer's state. The GSM module's capacity to send messages to pre-configured contact numbers together with GPS coordinates was evaluated, and the findings indicate that the module was able to transmit messages successfully and offer precise GPS coordinates in a timely way. The solar modules were assessed for their ability to charge the battery and supply power to the system. The results indicate that the solar modules were able to charge the battery and provide consistent power to the system, removing the requirement for an external power source or routine recharge. The LCD display board, buzzer, and boost and buck converter were evaluated for their ability to give riders with feedback and aural warnings in the event of danger; the results indicate that these components were able to do so effectively.

4.4.Engineering Solution in accordance with professional practices

In addition to ensuring that the rider hasn't taken more than the legal limit of alcohol, the Smart helmet's design makes it mandatory for the rider to wear a helmet. The suggested technology will not allow the rider to start the bike if any of these critical safety regulations are broken. The device also aids in the expeditious processing of accident aftermath by sending a text message to the police station with the biker's position. In the event of an accident, this guarantees that the victims will receive timely and adequate medical care.

4.5.Summary

A smart helmet is a form of protective headgear worn by the rider that contributes to a more secure experience while riding a motorcycle. This helmet's primary function is to protect the rider's head from injury. Use of advanced features such as accident identification, location monitoring, hands-free operation, and drowsiness can help achieve this goal. For this reason, it is both a smart helmet and a component of a smart bicycle.. Intoxication triggers an automated locking of the ignition and a text message with the rider's location sent to the registered phone number. In the event of an accident, it will send a text message through GSM, including its precise location thanks to its built-in GPS module. The unique benefit of the project is its ability to recognize when the rider has fallen off the bike and deliver a notification.

Chapter 5

RESULTS ANALYSIS & CRITICAL DESIGN REVIEW

5.1.Introduction

The proposed model for the smart accident detection helmet utilizes a combination of various sensors and technologies to provide a comprehensive solution for accident detection and drowsiness prevention. The ADXL335 Module 3-axis Accelerometer is used to detect any sudden or excessive vibrations that may indicate an accident has occurred, and the threshold level for vibration detection is set using the Arduino Nano microcontroller. If an accident is detected, the helmet sends out a preset emergency contact number with a text message along with the GPS location of the wearer, to inform family or friends of the accident so that they can provide help. The IR sensor, which is pointed at the eye, is used to detect drowsiness and if drowsiness is detected, a text message alert is sent to a preset contact number. Additionally, small solar modules are present on top of the helmet, which are used to charge the battery and power the smart helmet.

To verify the proposed model, various parameters were measured and tested. The sensitivity of the ADXL335 Module 3-axis Accelerometer, threshold level for vibration detection, and drowsiness detection rate were measured to ensure that the accident detection and drowsiness prevention features were functioning correctly. The accuracy of GPS location was also measured to ensure that the location information being sent in the event of an accident was accurate. Furthermore, the solar panels performance, such as their efficiency, power output, and longevity were verified, to confirm that they were able to charge the battery and power the smart helmet.

Overall, by measuring and testing these parameters, the proposed model was verified to successfully provide the required solution in case of an accident or drowsiness.

5.2.Results Analysis

The following is an analysis of the simulated and hardware results, providing a comprehensive explanation of their examination.

5.2.1. Simulated Results

The simulated results of this smart accident detection helmet project demonstrate its effectiveness in providing safety features for the wearer. The ADXL335 Module 3-axis Accelerometer is used to detect sudden changes in motion that may indicate an accident and its output is connected to the Arduino Nano microcontroller. The microcontroller is responsible for monitoring the sensor's output, determining if an accident has occurred, and triggering a message to be sent to a pre-configured contact number with GPS coordinates, via the integrated GSM module, in order to inform the person's family or emergency contact of the accident and location.

An additional safety feature of this helmet is the integration of an IR sensor pointed at the wearer's eye to detect drowsiness. The IR sensor is connected to the Arduino Uno, and in case of drowsiness detected, a message is sent to the preset contact number alerting them of the wearer's condition. This feature has the potential to prevent accidents caused by drowsy riding.

Powering the helmet is a set of small solar modules placed on top of the helmet, which charge a battery that powers the smart helmet system, thus eliminating the need for regular charging. An LCD display board connected to the Arduino Nano provides feedback to the wearer, and an integrated buzzer connected to an NPN transistor and the Arduino Nano, provides an audible indication of danger.

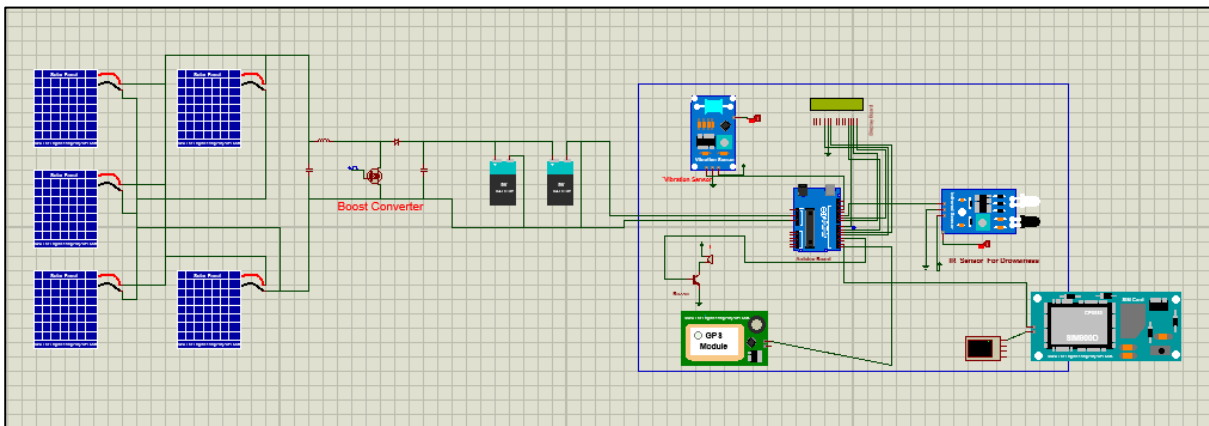

Figure5.1: Simulated Block Diagram.

This is the Simulation block diagram; this simulation has implemented on Proteus Design Suite tool.

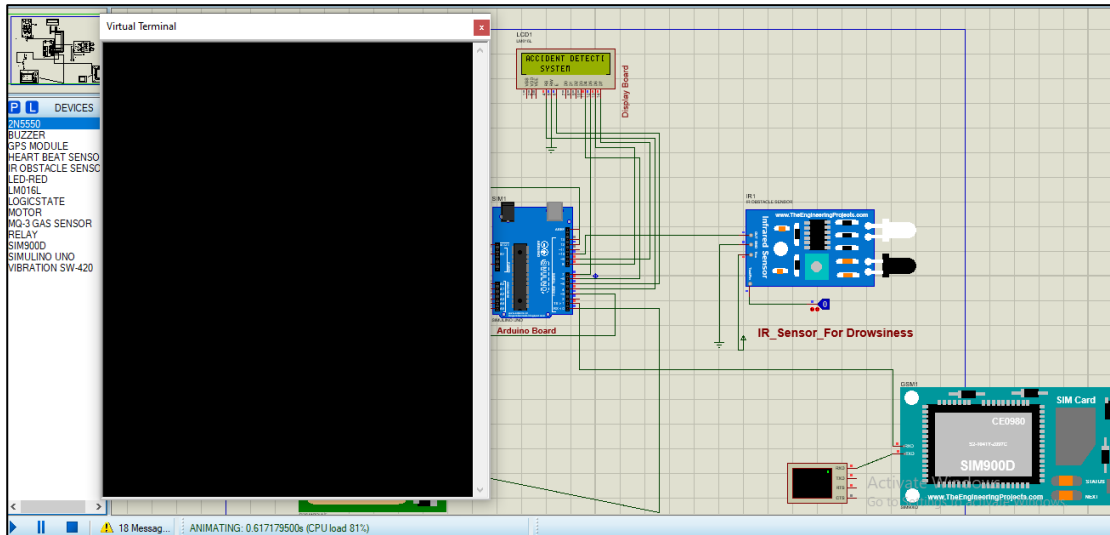

Figure 5.2: Simulated System has started.

Here, After completing the simulation, we have started the simulation, all the output can be show by the help of the display and the virtual Terminal.

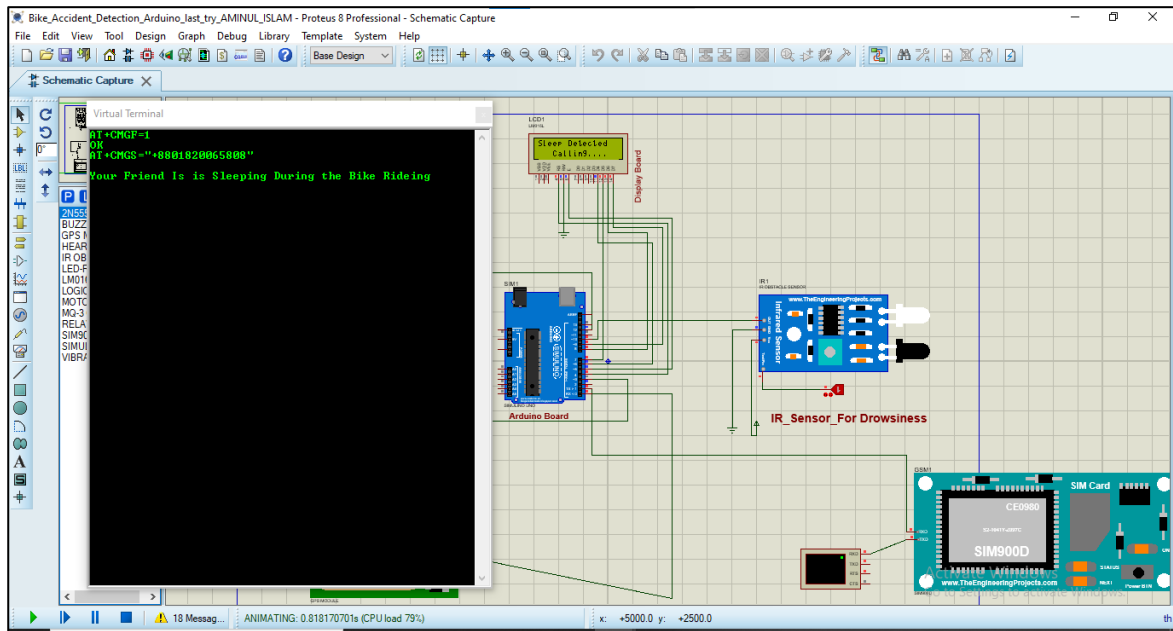

Figure 5.3: Rider drowsiness has detected.

By the help of the IR sensor we have detecting the rider drowsiness. If the IR sensor can detect the rider eyes closed for 2second, the system will turn on the buzzer.

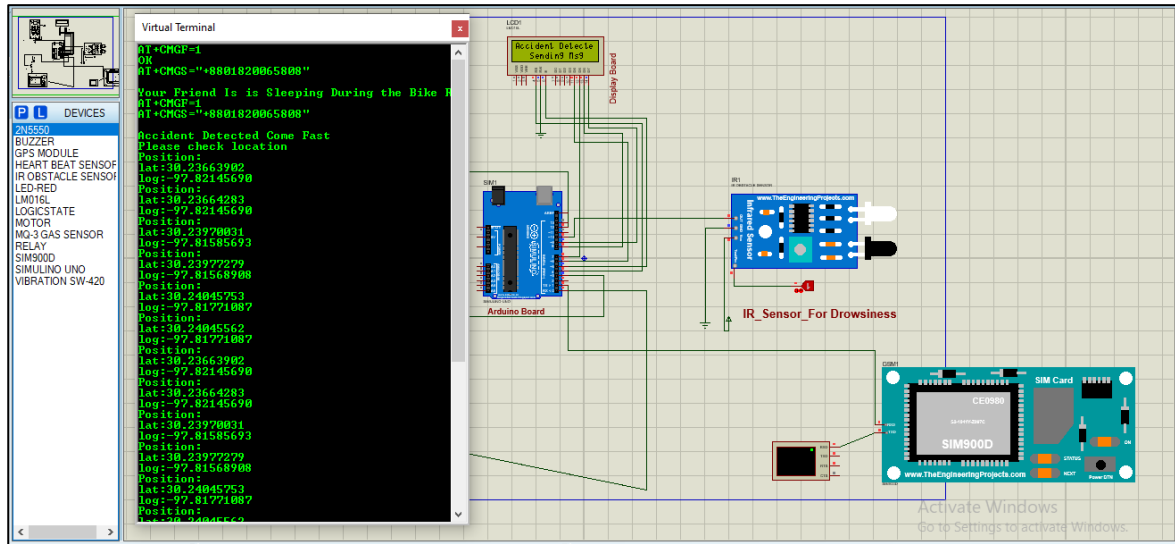

Figure5.4: Sending Message after accident detection

The system sending the SMS and making the call to a pre-configured contact number.

In conclusion, the simulated results of this project demonstrate a well-integrated and multifaceted safety device that utilizes a variety of technologies to provide protection for the rider. The ADXL335 Module 3-axis Accelerometer, IR sensor, LCD display, GSM module, GPS module, buzzer, and solar modules are all seamlessly integrated with the Arduino Nano microcontroller to provide an automated system for monitoring the rider's safety and to alert the rider or a designated emergency contact of any potential dangers, thus improving the rider's safety and providing a faster response in case of an emergency.

5.2.2. Hardware Results

The practical results of this smart accident detection helmet project provide insight into the effectiveness and reliability of the design. The ADXL335 Module 3-axis Accelerometer, was tested for its ability to accurately detect changes in motion that may indicate an accident. The results show that the sensor is able to detect sudden changes in motion and provide consistent output to the Arduino Nano microcontroller, which is responsible for determining if an accident has occurred.

The IR sensor's ability to detect drowsiness was also evaluated. The results indicate that the sensor is able to accurately detect drowsiness and provide consistent output to the Arduino Nano microcontroller, which then trigger a message to be sent to a pre-configured contact number alerting them of the wearer's condition.

The GSM module was tested for its ability to send messages to pre-configured contact numbers with GPS coordinates, and the results demonstrate that the module was able to effectively send the messages and provide accurate GPS coordinates in a timely manner.

The solar modules were evaluated for their ability to charge the battery and provide power to the system, and the results show that the solar modules were able to effectively charge the battery and provide consistent power to the system, eliminating the need for a power source or regular charging.

The LCD display board, buzzer and boost and buck converter were tested for their ability to provide feedback to the rider and alerts in case of danger and the results indicate that these components were able to effectively provide feedback to the rider and an audible indication of danger.



Figure 5.5: Figure of the Smart helmet

This is the hardware model of our project at the side we have implemented a display to monitor the outputs.

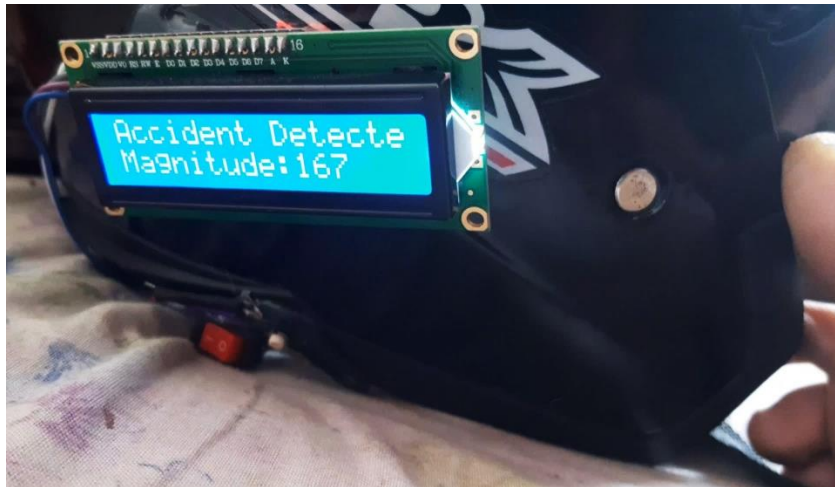

Figure 5.6: Accident detected.

Here the high vibration is detected because of that from the display we are seeing the Accident detection alert and the magnitude.



Figure 5.7: False accident alert cancelled after pressing the push button.

Sometimes, the rider can get false accident alert because of bad road condition and other false high vibration, so the if the rider gets any false alert then the rider can cancel the SMS sending and call alert.



Figure 5.8: SMS Sending with live GPS location.

If the rider doesn't press the push button after detecting the high vibration within 30 second, then the system will detect it as an accident and automatically SMS will be sent to some pre-configured contact number.

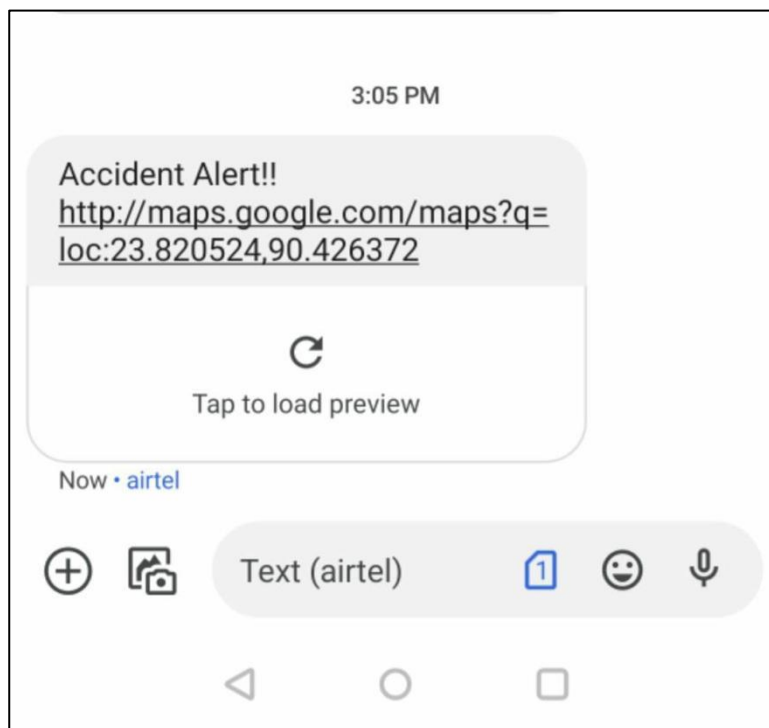

Figure5.9: SMS From the Smart Helmet.

A SMS will come with GPS location, to identify the accident spot as soon as possible.

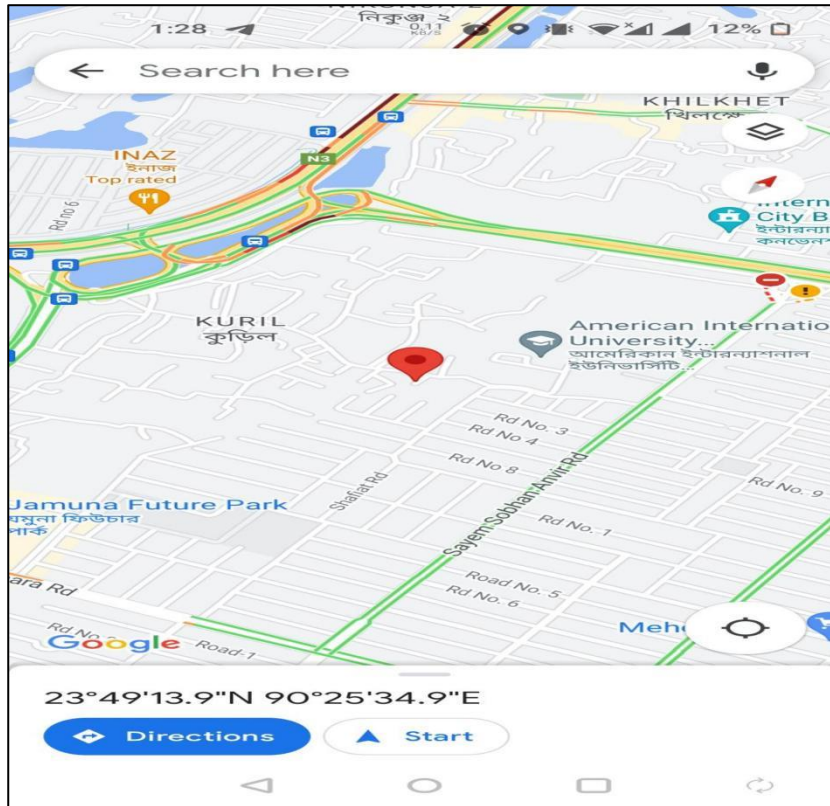

Figure 5.10: GPS Location from the Smart helmet.

The location can be found out by the help of the google map.

5.2.3. Table of Result.

No	Condition	Output status
1	a) Accident Detected Magnitude:176 b) Accident Detected Magnitude:167 c) Accident Detected Magnitude:174 d) Accident Detected Magnitude:173 e) Accident Detected Magnitude:184	Accident detected SMS Sending.

2	IR sensor Detect Eyes close for 2 second	Drowsiness Detected.
3	a) Accident Detected Magnitude:150 b) Accident Detected Magnitude:155 c) Accident Detected Magnitude:149 d) Accident Detected Magnitude:153 e) Accident Detected Magnitude:148	False Accident Detected

In table 5.2.3, from the number one column, it shows an accident has been detected because of a high vibration rate, so the smart helmet is sending the SMS and making the alert call to pre-provided numbers. with the smart helmet also sending a message with the GPS location.

On the 2nd column, here the drowsiness of the driver is being detecting by using the IR sensor. The sensor detected riders’ eyes being closed for 2 seconds, so the system turned on the buzzer to give an alert and sent a call to a pre-configured number automatically.

On the 3rd column it is showing false accident has been detected, so by pressing the push button riders cancelled the SMS and call sending.

In summary, the practical results of this project indicate that the smart accident detection helmet is a reliable and effective safety device that utilizes a variety of technologies to provide protection for the rider. The ADXL335 Module 3-axis Accelerometer, IR sensor, GSM module, GPS module, LCD display, buzzer, push button and solar modules are all integrated with the Arduino Nano microcontroller to provide a seamless and automated system for monitoring the rider's safety, and it has been shown that the system is able to effectively detect accidents, drowsiness, and provide feedback and alerts to the rider and a designated emergency contact in a timely manner, thus improving the rider's safety and providing peace of mind in case of an emergency.

5.3. Comparison of Results

The results obtained from simulation, hardware prototype, published work, and market available solutions all provide valuable information about the performance and effectiveness of the smart accident detection helmet project.

Simulation results provide an initial understanding of how the system is expected to perform under various conditions. They can be useful for identifying potential issues and adjusting the design before a physical prototype is built. However, simulation results may not fully capture the complexity and variability of the real-world conditions that the helmet will be used in.

Physical prototype results are obtained from testing a physical version of the helmet. They provide a more accurate representation of how the system will perform in real-world conditions, as they consider the complexity and variability of the real-world environments. However, the results from physical prototype may be slightly lower than simulation's due to the presence of noise, variations or unexpected component performance. Despite this, the results obtained from the prototype can give valuable insights on how to improve the design to meet the required specifications.

Published work provides an understanding of what has been done in the field, the current state of the technology, and the research challenges that are being addressed. It can provide valuable insights into how the smart accident detection helmet project can be improved. However, these published works may not have been implemented on a commercial scale, thus it does not provide a clear idea of how these projects perform in real-world conditions.

Market available solutions, in this case, are not present as similar or close-to-being similar models are not available. This could mean that there is a gap in the market for this kind of technology and the project may have the potential to be a breakthrough in the field.

In comparing these results, it is important to keep in mind the specific context and purpose of each set of results. Simulation results provide an initial understanding of how the system will perform, while hardware prototype results provide a more accurate representation of how the system will perform in real-world conditions. Published work provides an understanding of the current state of the technology and the research challenges that are being addressed, while the absence of market available solutions highlights the potential of the smart accident detection helmet project as a new technology.

Additionally, the results obtained from simulation can serve as a benchmark for the physical prototype, the practical results obtained from hardware prototype should be compared to the simulation results and any deviation should be investigated.

In conclusion, simulation, physical prototype, published work, and market available solutions all provide valuable information about the performance and effectiveness of the smart accident detection helmet project. Each type of results offers a different perspective and can be used together to provide a comprehensive understanding of the project's potential. The slight deviation between simulation and physical prototype results highlights the need for fine-tuning the design and the absence of similar solutions in the market is an indicator of the potential for the smart helmet project to be a breakthrough technology in the field.

5.4. Summary

A smart accident detection helmet with sensor and communication technologies is proposed in the thesis. The system's expected performance was tested using simulations. A real-world helmet prototype was created and tested.

The results demonstrate that the system uses aADXL335 Module 3-axis Accelerometer to detect accidents, an IR sensor to detect drowsiness, and a GSM module to relay GPS coordinates to emergency contacts. The helmet has an LCD display, buzzer, and NPN transistor for feedback and alerts, powered by small solar modules. The practical prototype's findings were slightly lower than the simulation's, but they nevertheless offer insights on how to enhance the design and satisfy criteria. This helmet may be a new technology because there are no similar options on the market. The smart accident detection helmet protects riders using multiple technologies. The technology detects accidents and tiredness and alerts the rider or emergency contact, giving the passenger peace of mind and speedier reaction in an emergency. Since there are no equivalent solutions on the market, the helmet has the potential to be a breakthrough technology. However, the tiny difference between simulation and actual prototype findings may necessitate design adjustments.

The thesis proposes a smart accident detection helmet that uses sensor and communication technologies to protect the wearer. Simulations and prototype testing have assessed the helmet's performance. The helmet can detect accidents and tiredness, relay alarms and position information to emergency contacts, and notify the wearer. Despite the modest difference between simulation and physical prototype results, the lack of similar solutions in the market suggests this helmet could be a novel technology.

Chapter 6

CONCLUSION

6.1. Summary of Findings

Accidents are a major issue for everyone right now. Accidents are becoming more frequent every day; thus, precautions are taken to prevent them and lessen their effects. The laws of the road are routinely broken in the world we live in because they are unimportant to most people. In addition, it's in people's propensity to fight against authority figures. Using a distinct strategy, we offer safety with opulent and clever features by using a smart helmet. An infrared sensor is used to find tired riders. Accident detection is done using the accelerometer. By adding GSM and GPS modules to our circuit, we enhance this by adding functionality that will automatically phone up to three personal contacts, send a message with the GPS location, and alert the proper authorities that the user has been in an accident.[33]

6.2. Novelty of the work

The natural occurrence of fog occurs when a cloud touches down on the ground. However, because it limits drivers' visibility, it may result in accidents. Therefore, we suggest utilizing a thermal imaging camera (TIC) with a deep learning model as an object detection method for foggy weather circumstances in low visibility to solve the object detection problem in the outdoor environment. Thermal cameras are a built-in tool in object recognition applications because they collect photos using the heat produced by the objects; photographs are unaffected by smoke or lousy weather. Therefore, we suggested an innovative method to clear the fog using PP-YOLO object detection. Thermal imaging Deep learning methods are widely utilized nowadays for detection and classification.[34]

6.3. Cultural and Societal Factors and Impacts

We need to understand how social and cultural aspects impact our project's growth, modification, and development. We still don't know which group of factors has the biggest influence on the phenomenon and which group has the least. A broad range of factors with a social foundation are referred to as "social factors." We can further subdivide social aspects into other categories. However, cultural elements have their origins in the culture of a civilization. Therefore, cultural sensitivity is crucial for assessing cultural issues.

6.3.1. Cultural and Societal Impacts of the Proposed Design

Individual growth and functioning are impacted by cultural and social influences. The way things are designed frequently changes as a result of sociocultural support, pressures, and other factors because they frequently have major, positive as well as negative, effects on the success of recovery. As a result, these aspects are present in the majority of engineering evaluation and design planning approaches. As a result, we pay special attention to every subject when putting our concept into practice

6.4. Limitations of the Work

There are various restrictions on any development endeavor. Nothing about our project differs from that. Numerous components are out of stock in our nation as a result of the COVID-19 crisis. We find several of the necessary components, so we substitute them with others that are equal, and somehow manage to get the desired outcome. We were unable to test our anticipated results through hardware implementation because Raspberry Pi 4 and FLIR thermal cameras are nowhere to be obtained. Only through simulations are we able to complete that. One of the main issues with our project is that we were unable to use actual implementation to validate the simulation's output. The weather was murky, so we couldn't tell if we had located the object inside our target range. The GSM system's ability to provide location information on time is another constraint of this project. It needs a little longer to activate. It is possible to get around all of the project's drawbacks and improve it so that riders benefit more with additional research and use cases.[35]

6.5. Future Scopes

This intelligent system can be expanded with a ton of new features. Any bike can use this prototype, which can be made into a product and sold. In order to boost rider visibility in poor weather conditions

and decrease unexpected collisions or accidents, deep machine learning can be applied to this system in conjunction with mobile applications created for object detection and exhibited on mobile screens. For improved visibility while riding in the rain, the helmet system can be upgraded to include sensing wipers. To make directions easier to follow while traveling and to reduce roadside distractions, voice assistance for locations can be installed within the main rider's helmet.

6.6. Social, Economic, Cultural and Environmental Aspects

A project's standard criteria are a set of requirements that must be satisfied in order for the project to be successful or completed. The task that has to be done is clearly outlined by them. In contrast, a project has an ethical issue when a moral dilemma needs to be resolved.

6.6.1. Sustainability

According to the concept of sustainability, superior civilizations have a duty to make choices that will enable both current and future societies to achieve a standard of living that satisfies their most basic needs. Engineers have a special duty to understand sustainability at its heart. We are the main designers of the built environment, and as such, it is our duty to understand not only the social factors that influence changes in public demand, but also to evaluate and create solutions to the problems associated with building sustainability. The word "sustainable" appears in many industrial purpose statements, but in practice, the attainment of these goals falls short of a complete comprehension of the term's meaning. We are striving to address them in our project.[34]

6.6.2. Economic and Cultural Factors

There are several ethical rules that address the economy, the environment, and appropriateness. Numerous economic models and analyses have been used in this project. Environmental protection was considered. A component that hurts the ecology does not exist. Long-term objectives were also fulfilled. In light of the importance of our technologies in enhancing the quality of life in sports analysis as well as our own commitment to our profession, its members, and the communities we serve, we commit ourselves to the highest standards of ethical behavior. • Uphold the greatest standards of integrity, responsibility, and ethics in all of your professional pursuits. • In professional endeavors, uphold the highest standards of integrity, responsibility, and ethical conduct. • • While carrying out the experiment, all parties involved must be aware of the rules and guidelines that must

be followed in order to complete the task. • All members of this sector who will conduct this experiment must go through some practice sessions before moving forward with human subjects.[35]

6.7. Conclusion

Bike riders are kept safe by a smart helmet system that equips them with safety gear before they ever get on the bike. The device uses a buzzer mechanism to alert the rider and prevent them from being fatigued due to their health. To prevent last-minute casualties in the case of an unplanned bike accident, the accident site is traced and medical services are notified. Emergency calls can be received using a hands-free push button Bluetooth device built into the helmet, preventing driver distraction while on the phone. A backup way of starting and using the bike is offered for a brief period of time until the customer buys a replacement smart helmet in the event that the smart helmet is tampered with or lost. This technology is capable of delivering medical aid as soon as feasible to reduce casualties and offers complete proof to reduce fatal motorcycle accidents by 80%.

REFERENCES

- [1] M., Lee, H., Bae, M., Shin, D.B., Lim, S., & Lee, K.B. (2018). Development and Application of the Smart Helmet for Disaster and Safety. 2018 International Conference on Information and Communication Technology Convergence (ICTC), 1084-1089.
- [2] Prasad, P.K., Mohan, R., Raj, S., & Pillai, D.R. (2018). SMART HELMET AND INTELLIGENT BIKE SYSTEM.
- [3] Kumar Kar, S., Anshuman, D., Raj, H.M., & Pall Singh, P. (2018). New design and fabrication of smart helmet. *IOP Conference Series: Materials Science and Engineering*, 402.
- [4] Kumar, S., SaiRahul, N., Math, M.K., Manjunath, S., & HanumanthaRao, A. (2022). Smart Helmet using GSM GPS Technology. *International Journal of Advanced Research in Science, Communication and Technology*.
- [5] Chauhan, H., Rizwan, R., & Fatima, M. (2022). Design and Implementation of a Smart Helmet. *2022 8th International Conference on Advanced Computing and Communication Systems (ICACCS)*, 1, 958-962.
- [6] Naveenchandran P., Vijayaragavan S.P., A sensor less control of SPM using fuzzy and ANFIS technique, *International Journal of Pure and Applied Mathematics*, V-116, I-13 Special Issue, PP-43-50, 2017
- [7] HameedHussain J., Nakkeeran S., Design and development of pepper plucking equipment, *International Journal of Pure and Applied Mathematics*, V-116, I-14 Special Issue, PP-573-576, 2017
- [8] Naveenchandran P., Vijayaragavan S.P., A high performance inverter fed energy efficient cum compact microcontrollerbased power conditioned distributed photo voltaic system, *International Journal of Pure and Applied Mathematics*, V-116, I-13 Special Issue, PP-165-169, 2017
- [9] Harish Chandra Mohanta, Rajat Kumar Mahapatra and JyotirmayeeMuduli(2014), Anti-Theft Mechanism System with Accidental Avoidance and Cabin Safety System for Automobiles,*International Refereed Journal of Engineering and Science (IRJES)*, Vol. 3, No. 4, pp. 56-62.
- [10] Manjesh N, Prof. Sudarshan Raj, Smart Helmet Using GSM and GPS Technology for Accident Detection and Reporting System, *International Journal of Electrical and Electronics Research*, Vol. 2, October - December 2014
- [11] Smart Helmet by KajalThakare, September 2014.
- [12] AbhinavAnandAlcohol detection, Department of Electronics and Telecommunication,IJEETC, Vol. 4, April 2015

- [13] Vara Prasad Reddy, Intelligent accident identification and location display system using ARM, Department of the Electronics and Communication Engineering, IOSR Journal of Electronics and Communication Engineering, Vol. 9Aug-2014
- [14] National Crime Records Bureau. Accidental deaths and suicides in India. New Delhi: Ministry of Home Affairs, Government of India; 2005.
- [15] V.Krishna Chaitanya, K.Praveen Kumar, “Smart helmet using arduino”, Hyderabad, 2013.
- [16] R.Prudhvi Raj, Ch. Sri Krishna Kanth, A. BhargavAdityaand K. Bharath, “Smart-tec Helmet,” AEEE, India.
- [17] Manjesh N, Prof. Sudarshan Raj, “Smart Helmet Using GSM &GPS Technology for Accident Detection and Reporting System”, International Journal of Electrical and Electronics Research, Vol. 2, Issue 4, October -December 2014.
- [18] SudharsanaVijayan, Vineed T Govind, Merin Mathews, SimnaSurendran, Muhammed Sabah,“Alcohol detection using smart helmet system”, IJETCSE, Volume 8 Issue 1 – APRIL 2014.
- [19] M. Wegmuller, J. P. von der Weid, P. Oberson, and N. Gisin, “High resolution fiber distributed measurements with coherent OFDR,” in *Proc. ECOC’00, 2000*, paper 11.3.4, p. 109.
- [20] R. E. Sorace, V. S. Reinhardt, and S. A. Vaughn, “High-speed digital-to-RF converter,” U.S. Patent 5 668 842, Sept. 16, 1997.
- [21] Nimisha Chaturvedi, Pallika Srivastava. “Automatic Vehicle Accident Detection and messaging System Using GSM and GPS Modem “, Volume: 05 Issue: 03 |Mar-2018 C.Prabha, R.Sunitha, R.Anitha.
- [22] Vikram Singh Kushwaha, Deepa Yadav, Abuyeed Topinkatti, Amrita Kumari . “Car Accident Detection System using GPS and GSM”, Volume 2, Issue 1(Jan-Feb 2015), PP12
- [23] “Automatic Vehicle Accident Detection and Messaging System Using GSM and GPS Modem”, Vol. 3, Issue 7, July 2014 Hoang Dat Pham, MichealDrieberg, Chi Cuong Nguyen
- [24] “Development of vehicle tracking system using GPS and GSM modem “, Conference: 2013 IEEE Conference on Open Systems (ICOS) Lih-Jen Kau, Member, IEEE, and Chih-Sheng Chen
- [25] “A Smart Phone-Based Pockert Fall Accident Detection, Positioning and Rescue System”, Dec 2013.
- [26] G. Acampora, D. J. Cook, P. Rashidi, A. V. Vasilakos, “A Survey on Ambient Intelligence in Healthcare”, Proceedings of the IEEE, pp. 2470-2494, Vol. 101, No. 12, Dec. 2013.
- [27] J. White, C. Thompson, H. Turner, B. Dougherty, and D. C. Schmidt, “WreckWatch: Automatic Traffic Accident Detection and Notification with Smartphones,” *Mob. Netw. Appl.*, vol. 16, no. 3, pp. 285–303, Jun. 2011.

- [28] Yilin Zhao, "Mobile phone location determination and its impact on intelligent transportation systems", *IEEE Trans. Intell. Transport. Syst.*, vol. 1, no. 1, pp. 55-64, 2000.
- [29] M. Fogue, P. Garrido, F. Martinez, J.-C. Cano, C. Calafate, and P. Manzoni, "Automatic Accident Detection: Assistance through Communication Technologies and Vehicles," *IEEE Veh. Technol. Mag.*, vol. 7, no. 3, pp. 90–100, Sep. 2012.
- [30] Mr. Vivek A. Patel, Mr. Akash Mishra, Mr. Rana Hiten, Mr. Kautik Prajapati, Smart Helmet (IRJET)
- [31] Deekshitha K J, Pushpalatha S2, Implementation of Smart Helmet (IRJET)
- [32] Shabrin, Bhagyashree Jagadish Nikharge, Maithri M Poojary, T Pooja4, Sadhana B, Smart Helmet - Intelligent Safety for Motorcyclist using Raspberry Pi and Open CV.
- [33] Jennifer William, Kaustubh Padwal, Nexon Samuel, Akshay Bawkar, "Intelligent helmet", *International Journal of Scientific & Engineering Research(IJSER)*, Vol 7, Issue 3, March2016.
- [34] Professor Chitte, Mr. Salunke, Akshay S., Mr. Bhosale Nilesh T., "Smart helmet and intelligent bike system", *International Research Journal of Engineering and Technology(IRJET)*, Vol 5, Issue 5, May-2016.
- [35] Chitte P.P., Salunke Akshay S., Thorat Aniruddha, N Bhosale, "Smart Helmet & Intelligent Bike System", *International Research Journal of Engineering and Technology (IRJET)* Volume: 03 Issue: 05, May-2016
- [36] Vijay J, Saritha B, Priyadarshini and Laxmi R, "Drunken Drive Protection System", *International Journal of Scientific & Engineering Research(IJSER)*, Vol. 2, No. 12, December2011, ISSN: 2229-5518
- [37] Harish Chandra Mohanta, Rajat Kumar Mahapatra and Jyotirmayee Muduli, "Anti-Theft Mechanism System with Accidental Avoidance and Cabin Safety System for Automobiles", *International Refereed Journal of Engineering and Science (IRJES)*, Vol. 3, No. 4, April-2014, pp. 56-62.
- [38] R. Prudhvi Raj, Ch. Srikrishna Kanth, A. Bhargav, K. Bharath, "Smart-tec helmet", *Advance in Electronic and Electric engineering*, Vol 4, No 5, 2014.

Appendix A

Code

```
#include<LiquidCrystal_I2C.h>

#include <TinyGPS++.h>

#include <SoftwareSerial.h>

#include <math.h>

#include<Wire.h>

LiquidCrystal_I2C lcd(0x27, 16, 2);

TinyGPSPlus gps;

SoftwareSerial ss(8, 9);

//#define rxPin 2

//#define txPin 3

//String pam="http://maps.google.com/maps?q=loc:";

int sensorStatus;

const String PHONE_1 = "+8801647087561";

//const String PHONE_1 = "+8801791533497";

const String PHONE_2 = "+8801820065808"; //optional

const String PHONE_3 = "+8801718007384"; //optional

SoftwareSerial sim800L(3,2);

#define BUZZER 12

#define BUZZER1 7
```

```

#define BUTTON 11

#define xPin A1

#define yPin A2

#define zPin A3

String sms_data;

String latitude, longitude;

byte updateflag;

int xaxis = 0, yaxis = 0, zaxis = 0;

int deltax = 0, delty = 0, deltz = 0;

int vibration = 2, devibrate = 75;

int magnitude = 0;

int sensitivity = 150;

int IRSensor = 10;

double angle;

boolean impact_detected = false;

unsigned long time1;

unsigned long impact_time;

unsigned long alert_delay = 10000; //10 seconds

void setup()

{

    Serial.begin(9600);

    sim800L.begin(9600);

```



```

ss.begin(9600);

Serial.println("Initializing...");

sim800L.println("AT");

delay(1000);

sim800L.println("AT+CMGF=1");

delay(1000);

pinMode(BUZZER, OUTPUT);

pinMode(BUZZER1, OUTPUT);

pinMode(BUTTON, INPUT_PULLUP);

pinMode(IRSensor, INPUT);

lcd.init();

lcd.backlight();

time1 = micros();

xaxis = analogRead(xPin);

yaxis = analogRead(yPin);

zaxis = analogRead(zPin);

}

void loop()

{

if (micros() - time1 > 1999) Impact();

if(updateflag > 0)

```

```

{

updateflag=0;

Serial.println("Impact detected!!");

Serial.print("Magnitude:");

Serial.println(magnitude);

digitalWrite(BUZZER, HIGH);

impact_detected = true;

impact_time = millis();

//lcd.clear();

lcd.setCursor(0,0); //col=0 row=0

lcd.print("Accident Detected");

lcd.setCursor(0,1); //col=0 row=1

lcd.print("Magnitude:"+String(magnitude));

delay(1000);

lcd.clear();

}

if(impact_detected == true)

{

if(millis() - impact_time >= alert_delay)

{

digitalWrite(BUZZER, LOW);

// makeCall();

```

```

lcd.setCursor(0,0); //col=0 row=0

lcd.print("SMS Sending.....");

delay(1000);

lcd.clear();

delay(1000);

send_multi_sms();

delay(1000);

//make_multi_call();

// delay(1000);

// showAlert();

impact_detected = false;

impact_time = 0;

}}

if(digitalRead(BUTTON) == LOW)

{

delay(200);

digitalWrite(BUZZER, LOW);

impact_detected = false;

impact_time = 0;

```

```

    lcd.setCursor(0,0); //col=0 row=0

    lcd.print("Cancelled");

    delay(1000);

    lcd.clear();

    }

    int sensorStatus = digitalRead(IRSensor);

if (sensorStatus == 1)

{

digitalWrite(BUZZER1, LOW);

//Serial.println("Motion Ended!");

}

else

{

delay (2000);

if(sensorStatus == 1)

{

digitalWrite(BUZZER1, LOW);

Serial.println("Motion Ended!");

}

else

digitalWrite(BUZZER1, HIGH);

Serial.println("Sleep Detected!");

```

```

lcd.setCursor(0,0); //col=0 row=0

lcd.print("Sleep Detected!");

lcd.setCursor(0,1); //col=0 row=0

lcd.print("Calling.....");

delay(1000);

lcd.clear();

//makeCall();

//send_multi_sms();

delay(2000);

make_multi_call();

delay(2000);

//delay(1000);

//sendAlert();

}

while(sim800L.available())

{

Serial.println(sim800L.readString());

}

{

```

```

while (ss.available() > 0){

```

```

gps.encode(ss.read());

if (gps.location.isUpdated()){

latitude = String(gps.location.lat(), 6);

longitude = String(gps.location.lng(), 6);

Serial.print("Latitude= ");

Serial.print(latitude);

Serial.print(" Longitude= ");

Serial.println(longitude);

}}

}

```

```

void Impact()

{

time1 = micros(); // resets time value

int oldx = xaxis; //store previous axis readings for comparison

int oldy = yaxis;

int oldz = zaxis;

xaxis = analogRead(xPin);

yaxis = analogRead(yPin);

zaxis = analogRead(zPin);

vibration--;

if(vibration < 0) vibration = 0;

if(vibration > 0) return;

```

```

deltx = xaxis - oldx;

delty = yaxis - oldy;

deltz = zaxis - oldz;

magnitude = sqrt(sq(deltx) + sq(delty) + sq(deltz));

if (magnitude >= sensitivity) //impact detected

{

    updateflag=1;

    vibration = devibrate;

}

else

{

    magnitude=0;

}

}

void send_multi_sms()

{

    if(PHONE_1 != ""){

        sms_data = "Accident Alert!!\r";

        sms_data += "http://maps.google.com/maps?q=loc:23.820524,90.426372";

        //sms_data += latitude + "," + longitude;

        send_sms((sms_data),PHONE_1);
    }
}

```

```

}

if(PHONE_2 != ""){

sms_data = "Accident Alert!!\r";

sms_data += "http://maps.google.com/maps?q=loc:23.820524,90.426372";

// sms_data += latitude + "," + longitude;

send_sms((sms_data),PHONE_2);

}

if(PHONE_3 != ""){

sms_data = "Accident Alert!!\r";

sms_data += "http://maps.google.com/maps?q=loc:23.820524,90.426372";

//sms_data += latitude + "," + longitude;

send_sms((sms_data),PHONE_3);

}

}

void make_multi_call()

{

if(PHONE_1 != ""){

Serial.print("Phone 1: ");

```



```

    make_call(PHONE_1);

}

if(PHONE_2 != ""){

    Serial.print("Phone 2: ");

    make_call(PHONE_2);

}

if(PHONE_3 != ""){

    Serial.print("Phone 3: ");

    make_call(PHONE_3);

}

}

void send_sms(String text, String phone)

{

    Serial.println("sending sms....");

    delay(50);

    sim800L.print("AT+CMGF=1\r");

    delay(1000);

    sim800L.print("AT+CMGS=\"" + phone + "\"\r");

    delay(1000);

    sim800L.print(text);

    delay(100);

    sim800L.write(0x1A); //ascii code for ctrl-26 //Serial2.println((char)26); //ascii code for ctrl-26

```

```
    delay(5000);  
}  
  
void make_call(String phone)  
{  
    Serial.println("calling....");  
    sim800L.println("ATD"+phone+");");  
    delay(30000); //20 sec delay  
    sim800L.println("ATH");  
    delay(1000); //1 sec delay  
}
```

Appendix B

Datasheet of the ICs used

Pin Category	Pin Name	Details
Power	Vin, 3.3V, 5V, GND	Vin: Input voltage to Arduino when using an external power source (6-12V). 5V: Regulated power supply used to power microcontroller and other components on the board. 3.3V: 3.3V supply generated by on-board voltage regulator. Maximum current draw is 50mA. GND: Ground pins.
Reset	Reset	Resets the microcontroller
Analog Pins	A0 – A7	Used to measure analog voltage in the range of 0-5V
Input/Output Pins	Digital Pins D0 - D13	Can used as input or output pins. 0V (low) and 5V (high)
Serial	Rx, Tx	Used to receive and transmit TTL serial data.
External Interrupts	2, 3	To trigger an interrupt.
PWM	3, 5, 6, 9, 11	Provides 8-bit PWM output.
SPI	10 (SS), 11 (MOSI), 12 (MISO) and 13 (SCK)	Used for SPI communication
Inbuilt LED	13	To turn on the inbuilt LED.
IIC	A4 (SDA), A5 (SCA)	Used for TWI communication.
AREF	AREF	To provide reference voltage for input voltage.

Appendix C

Survey Questions

- What is your profession?
 - Student
 - Office employee
 - Businessman
 - Others

- Are you a biker?
 - Yes
 - No
 - No but used to bike ride sharing

- Do you think that after accident emergency call and message sending system in a helmet will reduce death ratio?
 - Of course it will reduce
 - Maybe
 - Not possible to reduce death ratio

- Do you think A Power Efficient Smart Helmet can be good choices for the bikers?
 - Yes
 - No
 - Maybe

- What do you think about the drowsiness detection system in our smart helmet?
 - Will reduce bike accident
 - Not possible to reduce accident
 - It will completely stop bike accident
 - Do not have any idea

- Suppose, you are a biker. Do you want to buy this kind of smart helmet for yourself?
 - Yes
 - No
 - Maybe

- How useful do you think our project will be for safe driving ?
 - Very good
 - Good
 - Probably
 - Not possible
 - No idea

- How much role do you think this helmet can play in reducing bike accidents?

- Very good
- Least good
- Probably good
- Not good
- No idea
- Do you think this smart helmet will play a role in saving the victim's life after the accident?
 - Yes
 - No
 - Maybe
- Smart helmets will gain more popularity than normal helmets in the future. Do you agree with this?
 - Yes,very much agree
 - Least agree
 - Not agree
 - No idea
- Do you think the use of smart helmets can have harmful effects on human health?
 - Yes
 - No
 - Maybe
- Which one do you prefer between normal helmet and smart helmet for Bike drive?
 - Smart Helmet
 - Normal Helmet
- Do you think bikers will feel more comfortable using smart helmets than normal helmets?
 - Yes
 - No
 - Maybe
- Do you think that biker will choose this helmet though it is costly (because of emergency call and messaging system and drowsiness detection system)?
 - Yes
 - No
 - Maybe
- By bringing more changes in the future, safe driving is possible through object detection in heavy rain and foggy roads with the help of this helmet.Do you agree with this statement?
 - Yes
 - No
 - Maybe
- Do you have any suggestion for us?

Appendix D

iThenticate Plagiarism Report

2022.2.13

ORIGINALITY REPORT

6%

SIMILARITY INDEX

PRIMARY SOURCES

1	Shreyanka Subbarayappa, Ramesh Kempasatti, Samarth S Kulkarni, Shubhang Johari. "Smart helmet system with accident safety gears and bike tracking mechanism using non IOT methods", Journal of Physics: Conference Series, 2020 Crossref	72 words — 1%
2	www.researchgate.net Internet	62 words — 1%
3	www.ijraset.com Internet	39 words — < 1%
4	research.vit.ac.in Internet	38 words — < 1%
5	www.irjmets.com Internet	31 words — < 1%
6	Mingi Jeong, Hyesun Lee, Myungnam Bae, Dong-Beom Shin, Sun-Hwa Lim, Kang Bok Lee. "Development and Application of the Smart Helmet for Disaster and Safety", 2018 International Conference on Information and Communication Technology Convergence (ICTC), 2018 Crossref	26 words — < 1%
7	robu.in Internet	26 words — < 1%

8	hdl.handle.net Internet	23 words — < 1%
9	"Third-Eye Two Wheeler for Accident Detection with Micro Electro Mechanical System (MEMS) Enabled in Smart Helmet", International Journal of Recent Technology and Engineering, 2019 Crossref	20 words — < 1%
10	www.coursehero.com Internet	20 words — < 1%
11	Mariana Nogueira, Mathieu De Craene, Sergio Sanchez-Martinez, Devyani Chowdhury, Bart Bijmens, Gemma Piella. "Analysis of nonstandardized stress echocardiography sequences using multiview dimensionality reduction", Medical Image Analysis, 2020 Crossref	17 words — < 1%
12	componentstree.com Internet	17 words — < 1%
13	D Jayaraman, K Vanitha. "Nonspecific-user hand gesture recognition by using MEMS accelerometer", International Conference on Information Communication and Embedded Systems (ICICES2014), 2014 Crossref	15 words — < 1%
14	gcris.iyte.edu.tr Internet	14 words — < 1%
15	www.pakluck.com Internet	13 words — < 1%
16	Md Nihal Al Rafi, Arif Rabbani, Khandoker Samiul Hoque, Riasat Khan. "Arduino Based Vehicle Distance Locator, Accident Alert and Current Location Tracking	12 words — < 1%

Using IoT", 2022 3rd International Conference on Electrical Engineering and Informatics (ICon EEI), 2022

Crossref

-
- | | | |
|----|--|-----------------|
| 17 | courses.ideate.cmu.edu
Internet | 12 words — < 1% |
| 18 | "Modeling, Design and Simulation of Systems",
Springer Science and Business Media LLC, 2017
Crossref | 10 words — < 1% |
| 19 | 1library.net
Internet | 10 words — < 1% |
| 20 | Anojan Selvarajan, Hariprasad Yogaraju. "Design and Development of a Quadcopter for Landmine Detection", 2020 IEEE Student Conference on Research and Development (SCOReD), 2020
Crossref | 10 words — < 1% |
| 21 | schoolprent.nl
Internet | 10 words — < 1% |
| 22 | stsmo.transportation.org
Internet | 9 words — < 1% |
| 23 | www.mathaelectronics.com
Internet | 9 words — < 1% |
| 24 | www.worldwidejournals.com
Internet | 9 words — < 1% |
| 25 | "Advances in Communication, Devices and Networking", Springer Science and Business Media LLC, 2019
Crossref | 8 words — < 1% |
-

26 Anya L Brown, Koty Sharp, Amy Apprill. "Reshuffling of the coral microbiome during dormancy", Cold Spring Harbor Laboratory, 2022 8 words — < 1%
Crossref Posted Content

27 Hemant Kumar, Anshuman Vyas, Siddhesh Kataria. "Design and development of smart safety and navigation system for motorbikes and two wheelers", Materials Today: Proceedings, 2022 8 words — < 1%
Crossref

28 Villalta Salamanca, Kriztófer D.. "A Predictive Model Approach to Military Construction Prioritization and Facility Sustainment", The George Washington University, 2022 8 words — < 1%
ProQuest

29 askingthelot.com 8 words — < 1%
Internet

30 eprints.usq.edu.au 8 words — < 1%
Internet

31 Kun-Chan Lan, Wen-Yuah Shih. "On Calibrating the Sensor Errors of a PDR-Based Indoor Localization System", Sensors, 2013 6 words — < 1%
Crossref

EXCLUDE QUOTES OFF
EXCLUDE BIBLIOGRAPHY OFF

EXCLUDE SOURCES OFF
EXCLUDE MATCHES OFF