

# **IOT BASED ROBOTIC CAR WITH LIVE STREAMING SYSTEM**

An Undergraduate CAPSTONE  
ProjectBy

- |                         |                |           |
|-------------------------|----------------|-----------|
| 1. Al Tausif Mamun      | ID: 18-38044-2 | Dept: EEE |
| 2. MD Nazmul Sadik      | ID: 18-37933-2 | Dept: EEE |
| 3. Tanvir Sarkar Shefat | ID: 17-35181-2 | Dept: EEE |
| 4. Abdullah Hel Adnan   | ID: 18-38855-3 | Dept: EEE |

Under the Supervision of

**Prof. Dr. Muhibul Haque Bhuyan**  
**Professor**

**Fall Semester 2022-2023**  
**September, 2022**



**Faculty of Engineering**  
**American International University - Bangladesh**

# IOT BASED ROBOTIC CAR WITH LIVE STREAMING SYSTEM

A CAPSTONE Project submitted to the Faculty of Engineering, American International University - Bangladesh (AIUB) in partial fulfillment of the requirements for the degree of Bachelor of Science in their mentioned respective programs.

1. Al Tausif Mamun	ID: 18-38044-2	Dept: EEE
2. MD Nazmul Sadik	ID: 18-37933-2	Dept: EEE
3. Tanvir Sarkar Shefat	ID: 17-35181-2	Dept: EEE
4. Abdullah Hel Adnan	ID: 18-38855-3	Dept: EEE

**Fall Semester 2022-2023,  
September 2022**



**Faculty of Engineering  
American International University - Bangladesh**

## DECLARATION

This is to certify that this project is our original work. No part of this work has been submitted elsewhere partially or fully for the award of any other degree or diploma. Any material reproduced in this project has been properly acknowledged.

AIUB reserves the right to reuse/update any proprietary material designed and developed for this work.

### Students' names & Signatures

1. Al Tausif Mamun

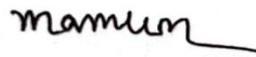

2. MD Nazmul Sadik

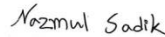

3. Tanvir Sarkar Shefat



4. Abdullah Hel Adnan



## APPROVAL

The CAPSTONE Project titled **IoT BASED ROBOTIC CAR WITH LIVE STREAMING SYSTEM** has been submitted to the following respected members of the Board of Examiners of the Faculty of Engineering in partial fulfillment of the requirements for the degree of Bachelor of Science in the respective programs mentioned below on **January 2023** by the following students and has been accepted as satisfactory.

- |                         |                |           |
|-------------------------|----------------|-----------|
| 1. Al Tausif Mamun      | ID: 18-38044.2 | Dept: EEE |
| 2. MD Nazmul Sadik      | ID: 18-37933-2 | Dept: EEE |
| 3. Tanvin Sarkar Shefat | ID: 17-35181-2 | Dept: EEE |
| 4. Abdullah Hel Adnan   | ID: 18-38855-3 | Dept: EEE |



-----  
Supervisor  
Prof. Dr. Muhibul Haque Bhuyan  
Professor  
Faculty of Engineering  
American International University-  
Bangladesh



-----  
External Supervisor  
Dr. Effat Jahan  
Assistant Professor  
Faculty of Engineering  
American International University-  
Bangladesh

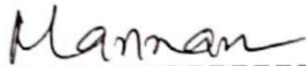

-----  
Prof. Dr. Md. Abdul Mannan  
Director  
Faculty of Engineering  
American International University-  
Bangladesh



-----  
Prof. Dr. ABM Siddique Hossain  
Dean  
Faculty of Engineering  
American International University-  
Bangladesh

# ACKNOWLEDGEMENT

We'd like to give Almighty Allah the credit for showering us with blessings as we worked on our thesis. We would like to thank Prof. Dr. Muhibul Haque Bhuyan, for taking the lead in this area of study and providing us with invaluable guidance, encouragement, and affection throughout the duration of this project. After that, we appreciate the help and guidance that our external supervisor, Dr. Effat Jahan, gave us so that we could take this thesis farther. Our sincere appreciation goes out to Dr. Carmen Z. Lamagna, Vice Chancellor, and Prof. Dr. ABM Sidd, Dean, both of American International University–Bangladesh, for their approval of this thesis.

We appreciate everyone's understanding and kindness throughout this time.

1. Al Tausif Mamun
2. MD Nazmul Sadik
3. Tanvir Sarkar Shefat
4. Abdullah Hel Adnan

# **TABLE OF CONTENTS**

DECLARATION .....	I
APPROVAL .....	II
ACKNOWLEDGEMENT .....	IV
LIST OF FIGURES .....	VII
LIST OF TABLES.....	VIII
ABSTRACT.....	IX
CHAPTER 1.....	1
INTRODUCTION.....	1
Overture.....	1
Engineering Problem Statement.....	1
Related Research Works.....	2
Earlier Research .....	2
Recent Research .....	4
Critical Engineering Specialist Knowledge.....	6
Stakeholders.....	6
Objective of this Work .....	7
Primary objectives .....	7
Secondary Objectives.....	7
Organization of Book Chapters.....	7
CHAPTER 2.....	8
PROJECT MANAGEMENT .....	8
Introduction.....	8
S.W.O.T. Analysis of the Project.....	8
Schedule Management.....	11
Cost Analysis .....	11
P.E.S.T. Analysis .....	12
Professional Responsibilities .....	13
Norms of Engineering Practice.....	14
Individual Responsibilities and Function as effective team member.....	15
Management principles and economic models.....	15
Summary.....	15
CHAPTER 3.....	16
METHODOLOGY AND MODELING .....	16
Introduction.....	16
Block Diagram and Working Principle .....	17
Modeling.....	18
Summary.....	18
CHAPTER 4.....	19

PROJECT IMPLEMENTATION .....	19
Introduction.....	19
Required Tools and Components .....	19
Implemented Models .....	23
Simulation Model .....	23
Hardware Model .....	23
Summary.....	24
CHAPTER 5.....	26
RESULTS ANALYSIS & CRITICAL DESIGN REVIEW.....	26
Introduction.....	26
Results Analysis .....	26
Simulated Results .....	27
Hardware Results.....	27
Comparison of Results.....	29
Summary.....	30
CHAPTER 6.....	31
CONCLUSION .....	31
Summary of Findings .....	31
Novelty of the work.....	31
Cultural and Societal Factors and Impacts .....	32
Engineering Solution in accordance with professional practices .....	24
Limitations of the Work.....	32
Future Scopes.....	33
Social, Economic, Cultural and Environmental Aspects.....	33
Sustainability.....	33
Economic and Cultural Factors .....	34
Conclusion .....	34
REFERENCES .....	36
APPENDIX A.....	40
DATASHEET OF THE ICs USED.....	40
APPENDIX B.....	48
I <small>T</small> H <small>E</small> N <small>T</small> I <small>C</small> A <small>T</small> E P <small>L</small> A <small>G</small> I <small>A</small> R <small>I</small> S <small>M</small> R <small>E</small> P <small>O</small> R <small>T</small> .....	48

# LIST OF FIGURES

FIGURE 1.0 1948-ELSIE (ELECTRO-MECHANICAL ROBOT, LIGHT SENSITIVE WITH INTERNAL AND EXTERNAL STABILITY)-W.[7] .....	3
FIGURE 1.1: SHAKEY FROM STANDFORDRESEARCH[7] .....	3
FIGURE 1.2: FIRST MARS ROVER MISSION[8] .....	4
FIGURE 1.3: UNDERWATER ROBOTS[8] .....	5
FIGURE 1.4: FIRE ROB FIREFIGHTING ROBOTS[9] .....	6
FIGURE 3.0: BLOCK DIAGRAM OF THE PROJECT .....	17
FIGURE 3.1: 3D RENDERING.....	18
FIGURE 4.0: ESP8266 CH340 NODEMCU WIFI MODULE LUA V3[21] .....	19
FIGUR 4.1: RASPBERRY PI 4[22] .....	20
FIGURE 4.2: ARDUINO UNO [23] .....	21
FIGURE 4.4: HUMIDITY SENSOR [25] .....	
FIGURE 4.6: DC WATER PUMP [27] .....	23
FIGURE 4.8: HARDWARE MODEL.....	24
FIGURE 5.0: SIMULATION RESULT .....	27
FIGURE 5.1: HARDWARE PROTOTYPE .....	27



FIGURE 5.2: RESULT ANALYSIS OF HARDWARE MODEL .....

29

## **LIST OF TABLES**

2.4. COST ANALYSIS .....	12
2.6.2.           INDIVIDUAL RESPONSIBILITIES AND FUNCTION AS EFFECTIVE TEAM MEMBER.....	14

## **ABSTRACT**

This paper details a fire-fighting robot that patrols its environment in search of flames and puts them out if it finds any. This is supposed to mimic how a real fire extinguisher machine might function in the workplace. In addition, the robot can transmit alerts to user-specified phone numbers. This project's main objective is to create a home monitoring robot. Robots are utilized in nearly every industry today, reducing the demand for human labor and minimizing the potential for error. Robots can be operated manually or automatically depending on the nature of the job at hand. The purpose of this mobile robot is to scout an area, record audio and video, and send that information back to the user. The IoT is used in this project so that a user can control the robot from their smartphone or laptop computer at any time of day or night and view live footage collected by the robot's built-in wireless camera. The robot's Arduino microcontroller allows for both hands-on control and fully autonomous operation. An Arduino microprocessor, fed by data from various sensors, determines the robot's actions. In addition to the live video broadcast, users can also use metal detectors to check for the presence of bombs. The process of monitoring can proceed. If we continue to develop this initiative, it will eventually be possible to conduct surveillance even in restricted military zones.

## Chapter 1

# INTRODUCTION

### Overture

The Internet of Things is becoming a reality in the exciting sector of control, thanks to the explosion of new technologies. There are a wide range of applications for IoT and AI, including smart transportation, security, and home automation. IoT is benefiting from wireless communication today [1]. It has been a few decades since robotics and automation made significant influence on both industrial and domestic applications. Robotics is widely used because it is able to make adjustments to systems that have already been built and because it is time-consuming. Proper surveillance is essential for the protection of people and their property. By utilizing a new aerial surveillance system, the surveillance system issues might be met in a more efficient manner. The current systems are expensive and difficult to use. As a result of technological advancements, the robotics and automation industry has undergone rapid and significant change across a wide range of applications [2]. Close, systematic observation or supervision of a person, group, etc., especially one being held in prison or suspected of a crime is known as surveillance. Consequently, it is necessary to keep an eye on sites such as the border and public places. It's primarily employed for keeping tabs on things. With the help of robots and other automation equipment, the act of surveillance can be conducted both inside and outside the building. An automated electronic machine that is capable of doing pre-programmed tasks and so substituting human labor, giving extremely accurate results, and easily overcoming the limits of human beings is referred to as a robot [3]. Thus, robotics has made a huge leap forward in the sphere of surveillance by substituting humans with robots.

### Engineering Problem Statement

The drawbacks of using traditional methods are acknowledged and changed. All sorts of automobiles can be fitted using this technology at a low cost. This technology is long-lasting and assures the safety of passengers and the general population. To put it another way, surveillance robots are employed to keep tabs on people's behavior, actions, and other information that can be used for the general aim of directing, safeguarding, or managing one's assets.

In order to complete this project, all of the aforementioned goals must be met. It's important to remember that as a final degree project, there are significant constraints on time, space, expense, and the author's knowledge that must be taken into account. In light of the short time frame, this project will rely heavily on the research conducted during the course of the project.[4] Examination of potential approaches and the early drafts of the prototype. if the moment and circumstances are right, It would be developed further with the best materials if the economic viability of the project was met.

## **Related Research Works**

Surveillance robots are becoming increasingly common. Both the algorithms and the navigation control System of wireless surveillance robots have undergone extensive development.[5] The inclusion of a camera on the robot for the purpose of receiving real-time video feed-back is another popular topic. All the evidence from the reports and studies point to the use of webcams[6]. One of our applications uses webcams to monitor disasters and terrorist attacks, which requires access to the internet. In these cases, a webcam is useless due to Internet traffic, so an AV camera is used instead, which operates on its own independent network. According to the documents, they employed the Internet or Bluetooth control for long-distance communication, but Bluetooth has a maximum range of only 10 meters.

### **Earlier Research**

Generally research works which are conducted and published 10 years before should be mentioned in this section. This sub-section should provide the historical background as well. If no research found 10 years then 5 years older research can be considered as earlier research work.

### **ELSIE (Electro-Light-Sensitive Internal-External)**

England in the 1950s. First mobile robot ever built, ELSIE (Electro-Light-Sensitive Internal-External). Technically, it could only do rudimentary things. It turned out to be a stable electromechanical robot with sensitivity to light. William Grey Walter, a neurobiologist and cybernetician, constructed electronic robots in the late 1940s. They were the first robots ever built with the intention of having free will and the ability to "think" like a biological brain. Because of their appearance and gait, Elmer and Elsie were frequently compared to tortoises. When exposed to light, they were able to move in a way known as phototaxis.

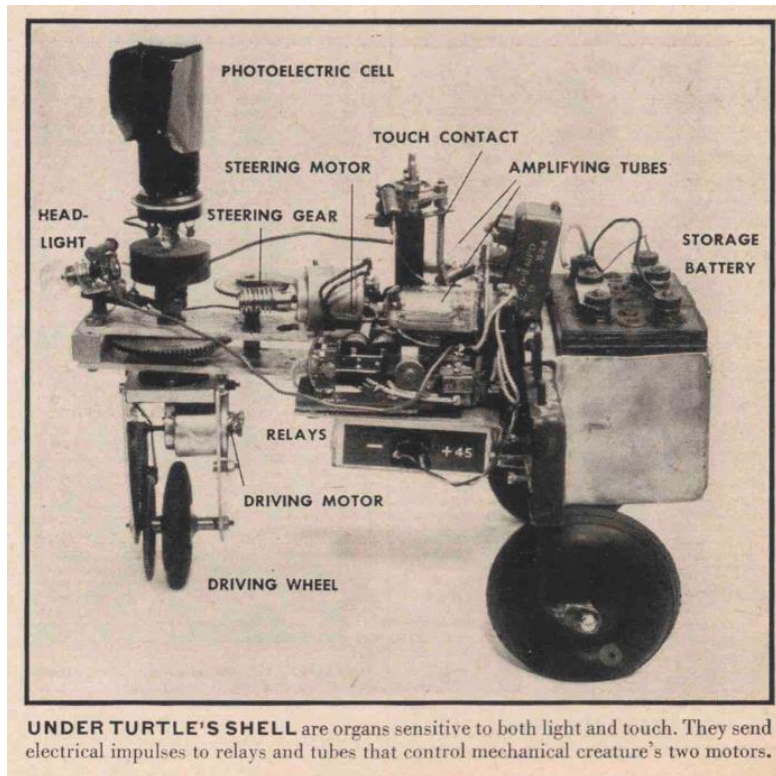

**Figure 1.0:** 1948-ELSIE (Electro-mechanical robot, Light Sensitive with Internal and External stability)-W.[7]

### **SHAKY Stanford Research Institute**

Shakey, the subject of study at SRI's Artificial Intelligence Center from 1966 to 1972,[7] was able to plan, navigate, and rearrange simple things. The robot, which is now on display at the Computer History Museum, has a profound impact on contemporary robotics and artificial intelligence.

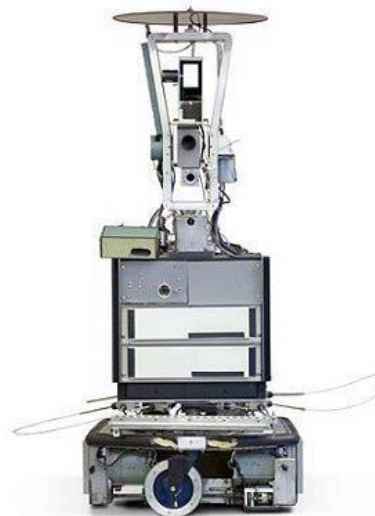

**Figure 1.1:** Shakey from standfordResearch [7]

## 1979 Mars Rover Mission

NASA planned to launch a Mars rover in 1979, not long after the Soviet Union landed its first robotic rover on the moon in 1970[7]. David Portree, a blogger for Beyond Apollo and a space historian, outlines the rover's design and capabilities that are still amazing today.

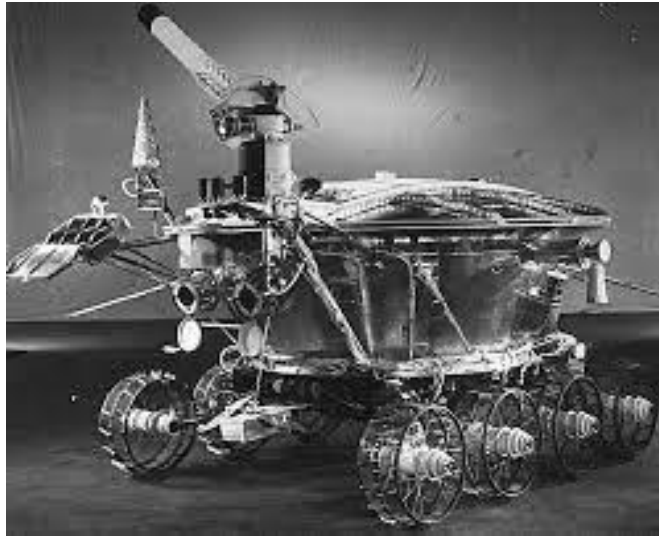

**Figure 1.2:** First Mars Rover Mission[8]

## Recent Research

Any related research which are generally not more than 5 years or 2 years old can be considered recent work. A clear indication should be there how the recent research complement the proposed project methodology.

## Underwater robots (unmanned underwater vehicles)

The majority of the time, unmanned underwater vehicles (UUV), also known as underwater robots, is used for military operations. Examples include mine-hunting robots and submarines. Underwater robots hold a lot of promise; among other things, they can be used for investigation and exploration as well as dam, tunnel, and pipeline inspection. The main focus of this research is on the civic uses of underwater robots, although there are a number of technological and practical hurdles. Technically speaking, the dangerous underwater environments have limited communication choices, poor vision, and a risk of animal attack. A few of the sensors, infrastructures, and navigation systems needed to manage these technical issues are sonar, acoustic altimeters, pressure sensors, cameras, and inclinometers. Underwater robots are expensive because of the high production expenses brought on by these sensors and technologies.

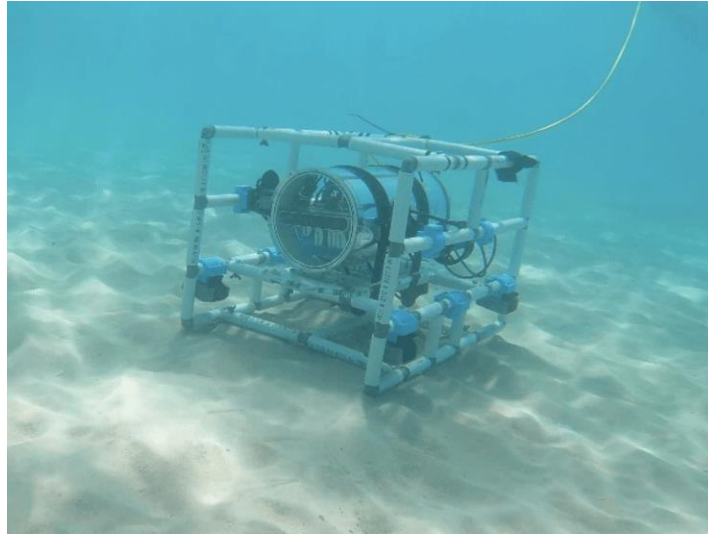

**Fig 1.3:** Underwater robots [8]

### **Service robots in logistics and delivery**

There is a rapidly expanding market for warehouse and logistics automation. One fascinating subset of this is the automation of motion-based tasks by mobile robots, autonomous vehicles, and drones. The term “logistics robotics” is used to describe the study of mobile robotic devices used in the logistics industry, including robotic carts/vehicles, on-road autonomous trucks, and drones, all of which aid in the transport of goods from one location to another.[8] Logistics and delivery robots have a bright future due to the market’s high demand and the technology’s minimal technological complexity. The market for service robots, where they have proven to be particularly useful, is projected to grow at a compound annual rate of 21% over the next decade.

### **FirefightingRobot**

Both the Thermite and FireRob firefighting robots are already available and have seen extensive use in the manufacturing sector.[9] Produced by Howe and Howe Technologies Inc, the firefighting robot Thermite can be operated from up to 400 meters away via a remote control. It has a maximum output of 1200 gallons per minute of water or 150 pounds per square inch of foam.



**Fig 1.4:** Fire Rob firefighting robots [9]

## **Critical Engineering Specialist Knowledge**

In order to design and create a robot that is capable to conduct reconnaissance missions and protect themselves as well as immobilize the target object, a surveillance robot equipped with a self-protection mechanism using a nail gun and the VDI (Association of German Engineers) method has been designed and is currently in the manufacturing/prototyping phase.[9] The prototype robot can transmit audio and video data using wireless Fi's connection (Wireless Fidelity). The robot has a self-defense system that includes a nail cannon that can rotate and elevate, making it a devastating weapon capable of paralyzing its prey.

## **Stakeholders**

Malls, businesses, and public spaces are gradually adopting the use of security robots. But while these bots are often portrayed as benign robots on patrol, taking the place of human security guards, the fact that they capture significantly more data than humans could indicates that they are more akin to mobile surveillance machines than traditional guards. Since Morpheme leases its robots rather than selling them completely, it may adapt each contract to meet the specific demands of its clients in terms of the data it is asked to collect. However, it's safe to assume that if you've ever come into physical contact with one of these gadgets, it has documented your existence in some way. The robots are ideal for this task. They keep at it with the tenacity of a tiger and the patience of a cog. They can operate nonstop, even in the dark thanks to their infrared cameras, and they make less of a public spectacle than human guards would. A robot's novelty will wear off after a few encounters, but after that, machines just become part of the scenery as they invisibly gather information in the background.



## Objectives

The following goals are intended to be achieved by conducting the related work:

### Primary Objectives

- To create a camera-equipped mobile robot that can be used to monitor
- To establish a console for navigation control using a Graphical user interface (GUI)
- To enable wireless communication between a robot and a computer.

### Secondary Objectives

- To collect sensors data and give values in real time.
- To movementArm in all directions, including servo motor motors
- To performs certain actions in response to a command given by the graphical user interface.

## Organization of Book Chapters

### Chapter-2: Project Management

In this Chapter, the project Gantt chart has designed in this project management chapter. Then, analysis the different related issues as such strength of this project, weakness and opportunities. Which Norm practice is has taken while doing the project along with all the individual responsibility were mentioned in this section.

### Chapter-3: Methodology and Modeling

In this methodology chapter, the proposed designed with block diagram were explained. 3D model with demonstration and the simulation and hardware result was shown as well subsequently.

### Chapter-4: Implementation of Project

In this the modified chapter, the proposed model will be described with details and other working mechanism. The description of primary used components was discussed.

**Chapter-5: Results Analysis & Critical Design Review** At last a result comparison was shown between simulation and hardware result.

### Chapter-6: Conclusion

Summary of the findings were discussed along with the novelty of this project and the limitations which were faced in this project. Future aspects and many impacts were mentioned as well.

## Chapter 2

# PROJECT MANAGEMENT

### 2.1.Introduction

Project management is a common method used to assure the success of a project. When it comes to project management, it's critical to have a clear picture of the objectives of the project, the resources this project needs, and achieve it. This chapter is all about getting down to business. The purpose of project management is to plan and execute a project in such a way that its stated goals and deliverables are met. Additionally, it includes the identification and control of potential risks, along with a thorough budgeting process and cross-organizational communication.[10] Project schedules can benefit from using the Gantt Chart. Money can be saved on the project's equipment by manipulating the data. Managing a project is a critical managerial ability. Planning, scheduling, and regulating actions to achieve a certain goal within a given time and budget are all part of the process. By completing initiatives that contribute to project aims, many businesses can meet the objectives. In most cases, projects have a specific start and end date, a specific number of participants, a specific number of resources, and a specific budget. This is planned and monitored by the group leader and adjusted just as needed.

### 2.2.S.W.O.T. Analysis

A project's opportunities and threats, as well as its strengths and weaknesses, can be analyzed using the SWOT framework. Using a functional approach, the internal analysis pinpoints the projects' strengths across the board (finance, management, infrastructure, procurement, production, distribution, marketing, reputational factors, and innovation) as well as its weaknesses (the same) and opportunities for growth (the same). Finding the source of competitive advantage requires a thorough internal study. In doing so, it identifies areas for investment in developing resources that will keep a team motivated. Potential advantages and disadvantages in the sector are uncovered through research on the surrounding environment, including the competition, the industry, and the broader economy. Analysis of the capabilities and assets of each competitor constitutes the competitive landscape. Competition, new entrants, suppliers, customers, and product substitution are analyzed as part of the industry's external

environment using the five Forces Model. Political, economic, sociological, technological, environmental, demographic, ethical, and regulatory repercussions are examined in the context of the external environment. The objective of doing a Strengths, Weaknesses, Opportunities, and Threats (SWOT) study is to inform a company's strategy development considering its specific context. In this using SWOT analysis, the strength and weaknesses are found.

### **Strengths**

- There is a large amount of sensor data about the status of the vehicle or the driver (e.g. tire pressure, engine diagnostics, fatigue monitoring)
- Combining the strengths of various sensors to form a complete picture of the vehicle's surroundings The use of many sensor types provides some protection against failure.
- The "fail safe operation" focus ensures the least dangerous possible condition when using the braking and steering actuation systems. There is no need for redundant function.
- Acknowledgement of increasing degrees of automation is bolstered by drivers' familiarity with state-of-the-art driving assistance technologies (Level
- Awareness of autonomous and connected vehicles is very high. Estimated favourable effects on traffic flow (efficiency, safety, sustainability)

### **Weaknesses**

- In practice, sensor data is applied in the context of particular endeavors.
- The integration of sensor data with meta information is still in its infancy (data exchange standards)
- However, fundamental studies are still required for accurate driver state sensing with reference to attention and, more importantly, intention (augmented sensing)

- Somewhat steep prices; constraints on coverage; limitations on resolution; delays in response; inaccuracies in detection; size constraints; etc.
- There is still a requirement to implement the full security design for vehicles.
- Inadequate measures have been taken to ensure the safety of automated and connected vehicles' networks
- Vehicles with linked and automated features are expected to cost a lot of money, and consumers are hesitant to shell out that kind of cash just yet.
- Disabling lack of agency/"freedom"

### **Opportunities**

- Advances in linked and automated functions may be achieved by repurposing preexisting sensor kinds and configurations.
- In-car sensing has the potential to pave the way for brand new markets (road condition data exchange, predictive maintenance, etc.)
- The number of different types of sensors can be reduced and a more dependable sensor setup defined by adopting standards.
- The data from various sensors and operations might be combined to provide a more comprehensive picture.
- The harmonization of laws inspires confidence in technological progress
- Constant dissemination of high-tech driving aids has boosted people's faith in modern gadgets.

## Threats

- Numerous suggestions for ensuring a stable system, including error-recovery mechanisms, etc.
- Despite advancements in satellite positioning systems and additional sensing, lane-level location still lacks accuracy within the time scope.
- Currently, there is no obvious technological roadmap. Complexity issues in the system could not be addressed in time.
- There will be no harmonization among the member states. incompatibility with other countries
- Concerns about security have been reinforced by recent events.

## Schedule Management

Project activities and tasks are organized using a schedule management structure, which uses time variables to do so. Outlines what has to be done for the project's completion to be on time and within the budget. Implementing a schedule management system is crucial to getting a project off the ground, tracking its progress, and ensuring that it is completed on time.

## Cost Analysis

The total cost analysis of both object detection and authentication devices is shown here. Here, the estimated price and the buying price of the components are shown.

S/L	Name Of Components	Quantity	Price
01	Node MCU	1pcs	680/-
02	MQ2	1pcs	200/-
03	Raspberry Pi 4	1pcs	20,000/-
04	Smoke Sensor	1pcs	157/-
05	Flam	1pcs	150/-
06	Motor driver	1pcs	250/-

07	PCB	1pcs	100/-
08	NTC Module	1pcs	100/-
09	Gear motor	4pcs	480/-
10	Wheel	4pcs	280/-
11	Camera module	1pcs	1050/-
12	Buzzer	1pcs	30/-
13	Jumper Wire	3set	290/-
14	Electric Wire	3ft	60/-
15	Resistor	5pcs	20/-
16	Glue stick	5p	100/-
17	Lead	100gm	180/-
18	PVC	1ft	300/-
19	3.7-volt Battery	3p	450/-
20	Switch	1p	15/-
21	Other		500/-
	Total		25,392/-

Now according to the standard deviation formula equation,

For standard deviation calculation,

Sum,  $\Sigma X$ : Online price (BDT) + Final expenditure price (BDT)

$$= 25,392$$

$$\text{Variance } \sigma^2 = \frac{1}{N} \sum (Xi - \mu)^2 = \frac{+ \dots +}{20} = \sqrt{\frac{25,392}{20}}$$

$$\text{Standard deviation} = \sqrt{\text{Variance}} = 35.63$$

## 2.5.P.E.S.T. Analysis

### Political Analysis

The analysis of political structures, institutions, ideas, and behaviors, and most importantly, the political processes through which they are constantly formed and changed, is made accessible and engaging in Political Analysis. This project won't require approval from the government to carry out its initiative. This project can be implemented without any restrictions.[11]

### **Economic Analysis**

Cost-benefit analysis is the core of the economic analysis. First, it uses economic viability to rate projects, so that funds can be distributed more efficiently. The purpose of this study is to evaluate a project's contribution to society. It is reasonable and cost-effective, and this project's initiative is to be accessible to everyone. The researchers need to keep the budget in mind throughout the implementation process.[12]

### **Social Analysis**

Analyzing stakeholder perspectives and priorities, and involving as many relevant stakeholders as possible in the development process, are all components of social analysis. This analysis is conducted in the context of the socio-cultural, institutional, historical, and political environment of Bank-financed operations. It's a team project and its target market may be affected by certain societal trends, behaviors, or attitudes. [13]

### **Technological Analysis**

Cameras and sensors have been featured in cars for some time now, aiding drivers' awareness of their surroundings and providing warnings to take preventative action in the event of a collision. Recently, technology has advanced to the point where it can act on behalf of a driver to avoid potentially disastrous situations including head-on crashes, backing into obstacles or traffic, or veering out of a delineated lane. The decisions made when driving, riding, and walking have a direct impact on public safety. However, modern automobiles can assist. Automobile safety is nowadays a great concern. So, the app-based authentication system now applies to most the smart vehicles to provide security.

## **Professional Responsibilities**

The concept of professional responsibility refers to the duty that persons in the professions who exercise their expertise to make decisions for the benefit of others or on their behalf must shoulder. It is imperative

that experts are seen to be taking reasonable precautions and being accountable for their work. The job of an engineer is to make sure that a system, method, or product is safe and effective. To make project a success, engineers must work well in groups and be able to work well with others. Engineers, customers, and businesses need to communicate effectively. Engineers are also responsible for the following:

- Using comprehensive drawings to draw out plans
- Preparing estimates and budgets for projects
- Defining the scope of the project
- Designing experiments in the field of engineering
- Producing customer-facing technical reports
- Completing safety-related regulatory documents
- On-time and within-budget completion of projects
- Informing clients and co-workers of findings and conclusions from the analysis

### **Norms of Engineering Practice**

Norms are the standards by which judges behavior. The goal of normative design is to find a happy medium between technological and ethical constraints in the context of design trade-offs. Engineers are compelled to consider the societal context in which their designs will be implemented when working to such stringent guidelines. One of the most important social values in the workplace is making workers feel appreciated. The engineering management team has a duty to actively improve their employees' abilities and knowledge. The best way to make employees feel like the company cares about them is to have an ongoing conversation focused on the employee's abilities, needs, improvements, and goals, as well as to create a solid development plan.

- Hold paramount the safety, health, and welfare of the public.
- Perform services only in areas of their competence.
- Issue public statements only in an objective and truthful manner.
- Act for each employer or client as faithful agents or trustees.
- Avoid deceptive acts.
- Conduct themselves honorably, responsibly, ethically, and lawfully so as to enhance the honor, reputation, and usefulness of the profession.



## Individual Responsibilities and Function as Effective Team Member

Name	ID No	Responsibility
Al Tausif Mamun	18-38044-2	Project lead & Chapter 5 and 6
MD Nazmul Sadik	18-37933-2	Hardware lead & Chapter 4 and 5
Tanvir Sarkar Shefat	17-35181-2	Software lead & Chapter 3 and 1
Abdullah Hel Adnan	18-38855-3	Simulation and designing Chapter 2

## Management Principles and Economic Models

Economists use models to generate testable hypotheses about economic behavior by simplifying their descriptions of reality. Due to the lack of a universally accepted standard for gauging economic performance, economic models are inherently subjective in nature. Economists will arrive at varying conclusions about what is necessary to explain the world as they see it. The two main types of economic models are theoretical and empirical. Under the premise that agents maximize specified objectives within well-defined model constraints (such as an agent's budget), theoretical models attempt to deduce provable implications regarding economic behavior. They give in-depth analyses of complex issues, including the effects of asymmetric knowledge (where one party to a transaction knows more than the other) and the most effective ways to deal with market failures. Empirical models, on the other hand, try to turn the qualitative predictions of theoretical models into more concrete numerical outcomes. For instance, if we were to use a theoretical model of an agent's consuming behavior, we may predict that the outlays would increase as their income did. The theoretical model would be empirically adapted to try to put a dollar amount on the typical percentage rise in spending that occurs with a percentage increase in income.

## Summary

Discussed in this section are the project's objectives, budget, task management, and SWOT analysis, as well as any potential dangers or advantages. Researchers can have faith in their decision to carry forward with the study because of what they have learnt from past initiatives and expense estimations. Due to the specified stakeholders, many more people will be able to take use of a wide variety of new possibilities.

## Chapter 3

# METHODOLOGY AND MODELING

### Introduction

In this study, researchers investigate the use of Internet of Things (IoT)-based robotics managed from a Smartphone and a personal computer for the purpose of observing and recording human activity. More and more people are looking for ways to make fire fighting robots safer and more effective. Finding the origin and spread of a fire requires clues can be gleaned from robot, smoke, and fire (thermal) reflections. The goal of this project is to create a robot fire truck that can be driven by hand or remotely controlled. The primary goal of this undertaking is to develop and deploy a firefighting robot, either automatically or manually. There are sensors on the robot that can pick up on things like fire, smoke, and impediments in its route. When compared to water, the gas spray on the suggested vehicle can put out fires far more quickly. Here, we describe a robot control system that may be implemented in many different kinds of robot tasks. Our goal is to design a covert robotic automobile capable of performing constant monitoring in potentially dangerous areas. Through its built-in wireless camera, the robot can capture live footage at any time of day or night. The user is responsible for manually directing the robot to do these actions. In a dangerous area where constant monitoring and security is required, this robot directly eliminates the need for human involvement. Multiple sensors, including a gas sensor, are all connected to an Arduino board to make up the full system. The robot can intercept data as it streams in and send it to an Android device. Remotely navigating the robot is possible thanks to WIFI connectivity and an Android application. As this initiative develops, spy robots will be used not only in the intelligence community, but also in the military and the mining industries. There is value in employing spy robots to keep a close eye on the border areas, which must be constantly monitored to protect the country from potential threats. The mechanical designs come first, then the hardware descriptions, and ultimately the software layouts. All the components were put together, and tests were run to establish the best distance at which to deploy it in order to put out the fire.

## Block Diagram and Working Principle

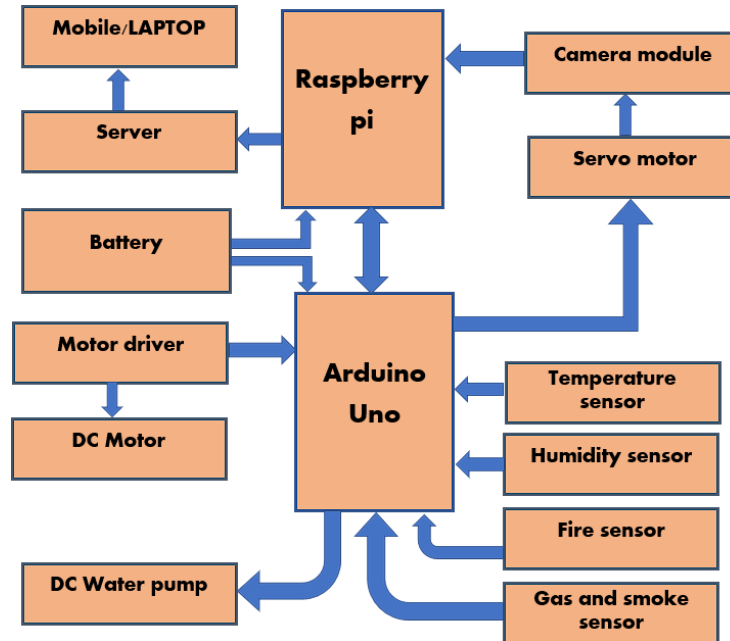

Figure 3.0: Block Diagram of the Project

This fire fighting robot is powered by a Bluetooth module, allowing for manual operation. A Bluetooth module allows for wireless connection to mobile devices. It is possible to set up the Bluetooth receiver to accept serial data sent from the Smartphone, allowing enabling the robot's operation to be governed by the smartphone. The robot's motion and pumping activity can be managed via a smart phone with the appropriate settings. In its fully automated mode, the robot is programmed to patrol an area for signs of fire and other hazards without any input from the operator. The machine roams the room looking for any indications of fire. Using the three flame sensors in its front, the robot will look for fires. As part of this plan, we installed smoke detectors and fire sensors to identify the presence of fire. Location of the fire's origin can be determined using an ultrasonic sensor. To get a sense of the surrounding environment, you can plug a USB camera onto a Raspberry Pi. The robot may switch between an automated and controlled state. Plug in the Raspberry Pi's power source. Connect your monitor to your Raspberry Pi with a VGA to HDMI connection. To utilize a USB mouse and keyboard with your Raspberry Pi, you must connect them via USB. Using the webcam robot can lessen firefighters' exposure to danger. We may put them to use in our homes, laboratories, workplaces, and factories to increase our ability to spot and put out fires before they spread out of control and threaten human lives. hence, This Robot Can Serve an Essential Role.

## Modeling

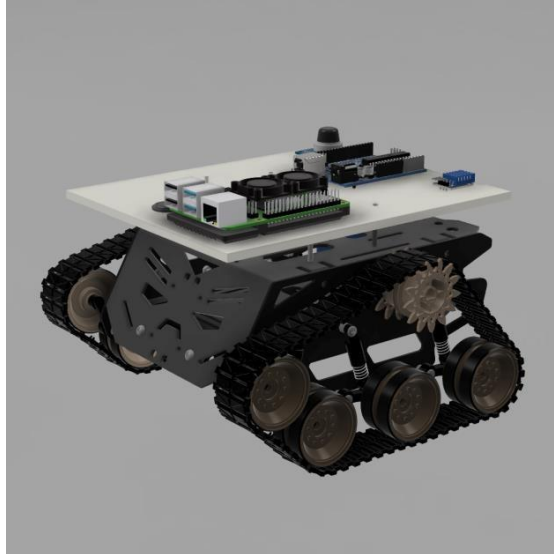

Figure 3.1: 3D Rendering

A 3D model was made using fusion 360 software to illustrate the final prototype of the project. Almost the exact design was made in the software before implementing the hardware.

## Summary

Loss of life, destruction of property, and lifelong injury or disability is all possible outcomes of a fire occurrence. Unfortunately, major fire catastrophes do occur in high-risk businesses including nuclear power plants, petroleum refineries, gas tanks, chemical factories, and others of a similar nature. There have been thousands of fatalities due to such incidents. Therefore, a robotic vehicle for fire control is being developed as part of this project. Robots are increasingly employed for security as the field of robotics develops, reducing the need for human involvement. Fires are a normal occurrence in daily life, and saving lives for firefighters can be challenging at times. A robot designed to put out fires is one possible solution.

## Chapter 4

# PROJECT IMPLEMENTATION

### Introduction

The discipline of robotics and automation, which covers a wide variety of applications, has been transformed dramatically and rapidly by technological advancements in recent decades. Close observation, or surveillance, is the method through which the practice of keeping someone (or something) under constant watch, as is done, for example, with a suspect or detained population. Thus, it is necessary to conduct surveillance primarily in regions like airports, ports, public squares, and workplaces and factories. Its primary function is to keep tabs on goings-on. Surveillance can be conducted in both indoor and outdoor settings, either manually or with the aid of embedded technologies like robots and other automation devices. A robot is simply an electronic machine that can be programmed to carry out certain tasks, eliminating the need for human labor while also improving upon human capabilities in terms of precision, speed, and endurance. In this way, one of the greatest achievements of robotics is the ability to replace people in surveillance domains. The robot's brains, or microprocessor, are an Arduino Uno. In addition to the ultrasonic sensor for obstacle detection and the infrared sensor for identifying pits, this robot also features DC motors, a wheel chassis, a battery, a Wi-Fi module (ESP8266 12e), and several sensors. Robot can be programmed for autonomous or human-controlled operation. Using the IoT protocol, the user's end can have two-way conversations with the robot.

### Required Tools and Components



Figure 4.0: ESP8266 CH340 NodeMCU Wifi Module Lua V3[21]

NodeMcu ESP8266 V3 Lua CH340 Wifi Dev board Is based on LUA, which is a modern, high-level, mature language.[21] It's a streamlined machine that has everything it needs built right in. Integrating it into your current Arduino work, or that of any other development board with accessible I/O pins, is a breeze. The built-in API of the NodeMCU can be leveraged by modern Internet development tools like Node.js, speeding up the implementation of your brilliant idea. NodeMCU was developed on the tried-and-true ESP8266 platform so that its users may tap into the vast online data pool. Built-in USB-TTL serial with extremely dependable industrial quality CH340 ensures NodeMCU's outstanding stability across all supported platforms, and the ESP-12 based serial WiFi on board makes GPIO, PWM, ADC, I2C, and 1-WIRE readily available. When compared to other wifi-modules, this one is really affordable. The most recent version of this component is V3, also known as Version 3.

## **Raspberry Pi 4**



Figur 4.1 : Rasberry Pi 4 [22]

The Raspberry Pi operating system (formerly known as Raspbian) is highly recommended for everyday use. A microSD card preloaded with Raspberry Pi OS or another operating system is quickly and easily created with Raspberry Pi Imager [22]. The online Getting started guide will assist you in setting up your Raspberry Pi and installing the Raspberry Pi operating system. You can learn the basics of using the Raspberry Pi and its operating system by perusing some of the software provided as examples, learning more about the OS itself, or reading up on the fundamentals of Linux usage and commands for accessing the file system and managing users. Raspberry Pi 4 has passed rigorous compliance testing and is in accordance with many national and international specifications. Consult and save any applicable conformance documentation and certificates. Trademarks or registered trademarks of HDMI Licensing Administrator, Inc. in the United States and/or other countries are used in connection with the Adopted Trademarks HDMI, HDMI High-Definition Multimedia Interface, and the HDMI Logo.

## **Arduino Uno**



Figure 4.2: Arduino Uno [23]

The ATmega328 forms the basis of the Arduino Uno R3, which is a microcontroller board (datasheet). It comes with a USB port, a power jack, an ICSP header, a reset button, and 14 digital I/O pins (6 of which can be utilized as PWM outputs). It has everything someone need to get started with the microcontroller; all one has to do is plug it into a computer through USB or supply power via AC-to-DC converter or battery.[23]

### Raspberry Pi Camera Module V2-8



Figure 4.3: Raspberry Pi [24]

The Sony Exmor IMX219 sensor-based Raspberry Pi Camera Module 2 supports 4K at 30 frames per second, 1080p at 60 frames per second, 720p at 180 frames per second, and 8 megapixel still images with a resolution of 3280 by 2464 [24]. Raspberry Pi Board 2A Power Supply Supports Up to 1080p30 Video and 8MP Stills Advised without Reservations hose products that come with plugs are only suitable for usage in the United States. Some countries use a different voltage standard than the United States, so you may need a voltage converter or adapter to utilize your electronics there.

## Humidity Sensor



Figure 4.4: Humidity Sensor [25]

Most standard electric resistance variable humidity sensors rely on hydrocarbon polyelectrolyte for their moisture sensing material. Because of this, sensors often cannot be utilized in environments with temperatures of 60 °C or higher due to a lack of heat resistance. In addition, they quickly decay when exposed to atmospheric cigarette smoke and oil [64,65]. The electrical resistance dropped rapidly when air was breathed on the fluorinated pitch-deposited coating, but it rose again as soon as the breathing ceased. Then, it was attempted to create a humidity sensor that is particularly sensitive to humidity responses, resistant to heat, and long-lasting. Vacuum deposition of fluorinated pitch was used to produce a thin film on two types of comb-like electrodes with varying electrode spacing.

## Fire sensor



Figure 4.5: Fire Sensor [26]

Supply Voltage, Output Channel 1: 3.3V5 V There is a built-in potentiometer for sensitivity control. When the signal is high and being output from the board, the indicator lights up and the output signal can be connected straight to the IO of a microcontroller. [26] The flame spectrum is particularly sensitive to such gradations, and detection requires just around a 60-degree field of view. The fire alarm is one of the most sensitive sensors and can even react to regular lights.



## DC water pump



Figure 4.6: DC water pump [27]

This DC 2.5 6V Mini Micro Submersible Water Pump is a low-priced, compact Submersible Pump Motor that operates on a voltage range of 2.5 6V. At only 220mA, it uses extremely little power and can handle up to 120 liters of water per hour.[27] To use, plug the tube pipe into the motor's power port, then place it in a watery environment.

## Implemented Models

### Simulation Model

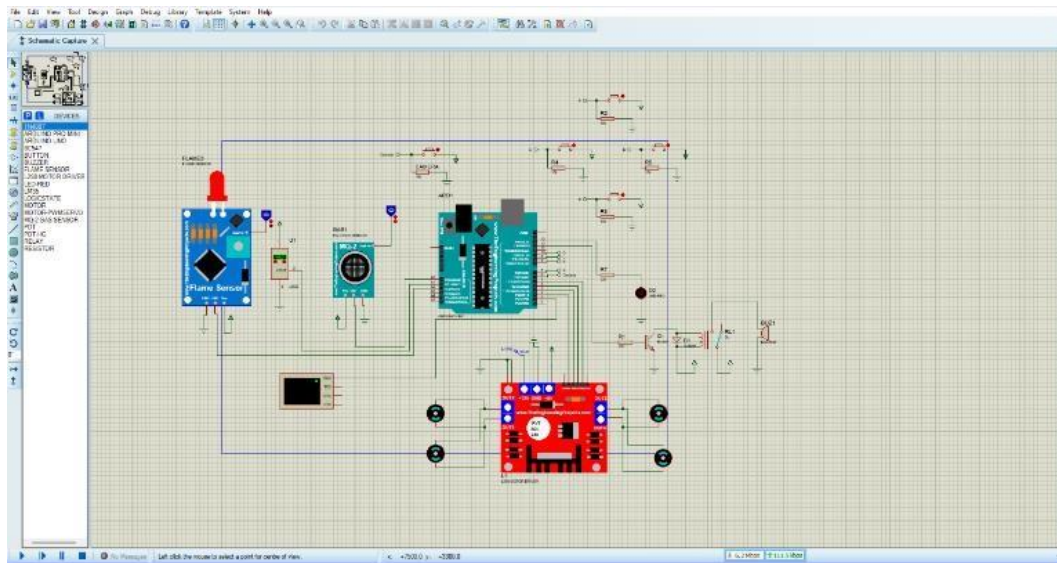

Figure 4.7: Proteus Simulation

### Hardware Model



Figure 4.8: Hardware Model

Designed to aid firefighters in high-rise fires, the Firefighting Robot is a lightweight and portable emergency response robot.

### **Engineering Solution in accordance with professional practices**

The Firefighting Robot is a lightweight emergency responder robot that helps firefighters battle blazes in high-rise buildings, especially in dangerous conditions where human firefighters should not put their lives in danger. Water is sprayed onto the fire thanks to a servo motor that guides the water pump's hose in the right direction. The pump uses water from the associated tank to spray into the flames, putting an end to the fire. The driven/steering wheel arrangement is bulky and has a high propensity for cable tangles since the motor must be transported with the wheel.

### **Summary**

Simply said, a robot is an automated machine that can be instructed to perform a task that would normally be handled by a human worker or by another robot. Numerous studies have shown that robots can be helpful in many different fields, including healthcare, rehabilitation, rescue operations, and manufacturing. As the technology has advanced, robotics has found use in a wide variety of fields. Industrial robots' programmed actions allow them to deftly manipulate a wide array of parts, materials, and gadgets. In line with the ideals of the 4th Industrial Revolution (or 4IR), a standardized system is required for the management and coordination of several robots with different strengths and weaknesses. Machine learning has also stimulated interest in robots, albeit it cannot be directly credited with all of the

progress that has been made in this area recently. Machine learning strategies have recently been implemented in robotics R&D in an effort to improve robot intelligence. In the long run, this will cut down on costs and electronic waste while increasing manufacturing output. Research on the use of humanoid robots in firefighting is ongoing in an effort to improve the safety, efficiency, and quality of the job while decreasing the number of fatalities and injuries that occur in the line of duty. There is a wide variety of robots available nowadays. Tele-robots, telepresence robots, mobile robots, autonomous robots, and android robots are all examples of this type of robot. A tele-robot and a tele-presence robot are fundamentally different in that the latter gives feedback in the form of audio, video, and other information. This has led to the increased use of tele-presence robots in a wide range of applications where constant monitoring is required, such as in the care and education of young children and the improvement of the quality of life for the elderly. The mobile robot is controlled by humans while it travels and does tasks. Unlike android robots, which are programmed to mimic human behavior, autonomous robots may function independently and obtain power from their environment.

## Chapter 5

# RESULTS ANALYSIS & CRITICAL DESIGN REVIEW

### Introduction

A fire incident is a catastrophic event that can result in death, extensive property destruction, and long-term medical complications for those who survive. Additionally, they are susceptible to experiencing chronic trauma, both mental and physical. Firefighters' main responsibility is putting out fires, but they face increased dangers in high-risk settings including nuclear power plants, oil refineries, and gas storage tanks. In addition, they confront additional challenges, especially when fires break out in confined spaces, as they must investigate the wreckage of structures and obstructions to put out the fire and rescue the victim. Even though firefighting operations present difficult challenges and dangers, technological advances can be used to help put out fires. As a result, this study details the creation of a robot called QRob that can put out fires without putting firefighters in harm's way. QRob is built to be smaller than traditional fire-fighting robots, making it easier to enter small locations and extending the robot's reach when putting out fires. A flame sensor is fitted to QRob in case of fire, and an ultrasonic sensor prevents it from colliding with obstacles and nearby items. As a result, QRob proved its ability to autonomously detect fires and put them out from a distance. QRob has been trained to locate the fire and halt no more than 40 cm away from it. Cameras that connect to smartphones or other remote devices allow humans to keep an eye on their robots from afar.

### Results Analysis

Analyzing results in each topic on the course outline can give various insights into the progress and comparison methods. It can be utilize the data to zero in on the areas of most needed.Both Simulation and hardware Result will be shown here along with various validity and results.

## Simulated Results

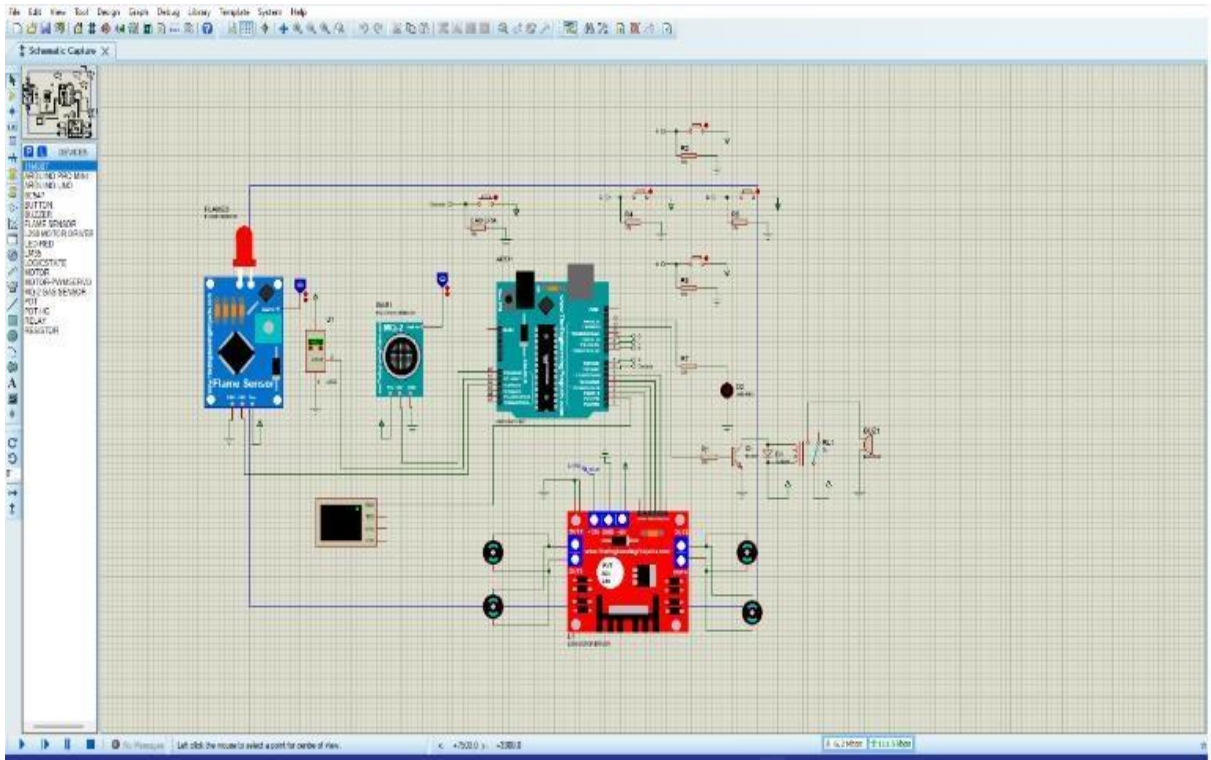

Figure 5.0: Simulation Result

## Hardware Results

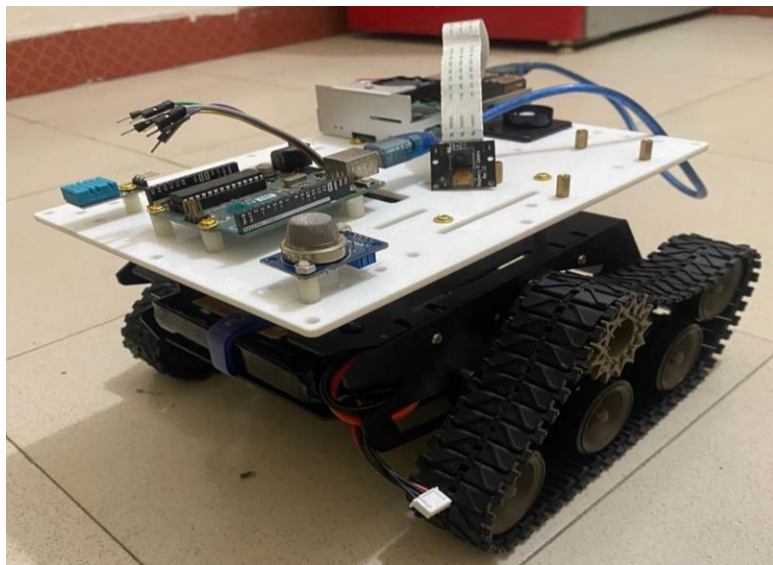

Figure 5.1: Hardware Prototype

This robot meant to enter a room and seek out an area in which there is heat potentially due to a fire. As soon as it enters the room, the robot will utilize its color camera to zero in on a location where there is an abnormally high number of

Once the robot has arrived at the light, it will activate its heat sensor to determine if there is significant heat production. When the temperature gets too high, a servo motor spins the fan at high speed to extinguish the fire. The fan will restart and blow on the flame if it is not extinguished. When the fire is out, the robot will leave the house. A sensing device capable of detecting temperature is what makes up the temperature sensor. When the temperature rises above a certain threshold, the LCD displays will alert the user with the message "TEMPERATURE DETECTED."

The same job can be done with an LDR sensor. It's also controlled by an ArduinoUno microcontroller. This is helpful since it allows for rapid access to comments and Proteus code. Both analog and digital signals are included here. The temperature and LDR sensors are linked to the A1 pins of the proposed A0 firefighting robot. There are a total of five relays in this robot; four of them control movement, and one activates DC motors that spray water automatically if a fire is detected. GSM is also utilized to automatically dial the pre-stored phone number in the event of a fire detection. This will ensure that the appropriate individual receives the notice and may take the required actions to ensure his own safety. The robot that fights fires is made up of several different parts. One type of sensor. Often used as a warning of impending fire, a smoke alarm is a device that scans or detects smoke. When smoke is detected, commercial, industrial, and very large residential devices all send a signal to the fire alarm system. In contrast, fire detectors used to search for flames before they were shot out, before the smoke came out. In this aspect, it is vastly superior to conventional smoke alarms. Infrared (IR) sensors detect the heat of the flame and send the data to a microcontroller. An Infra-Red sensor can detect motion and estimate the temperature of an object or material. "Passive IR sensors" are a sort of detector that detects infrared light but doesn't produce any of its own.

If the IR receiver isn't getting a signal, the comparator's output won't light up until the comparator's input inverts, which happens when the LED's potential is considerably higher than the non-inverting reversing input's.

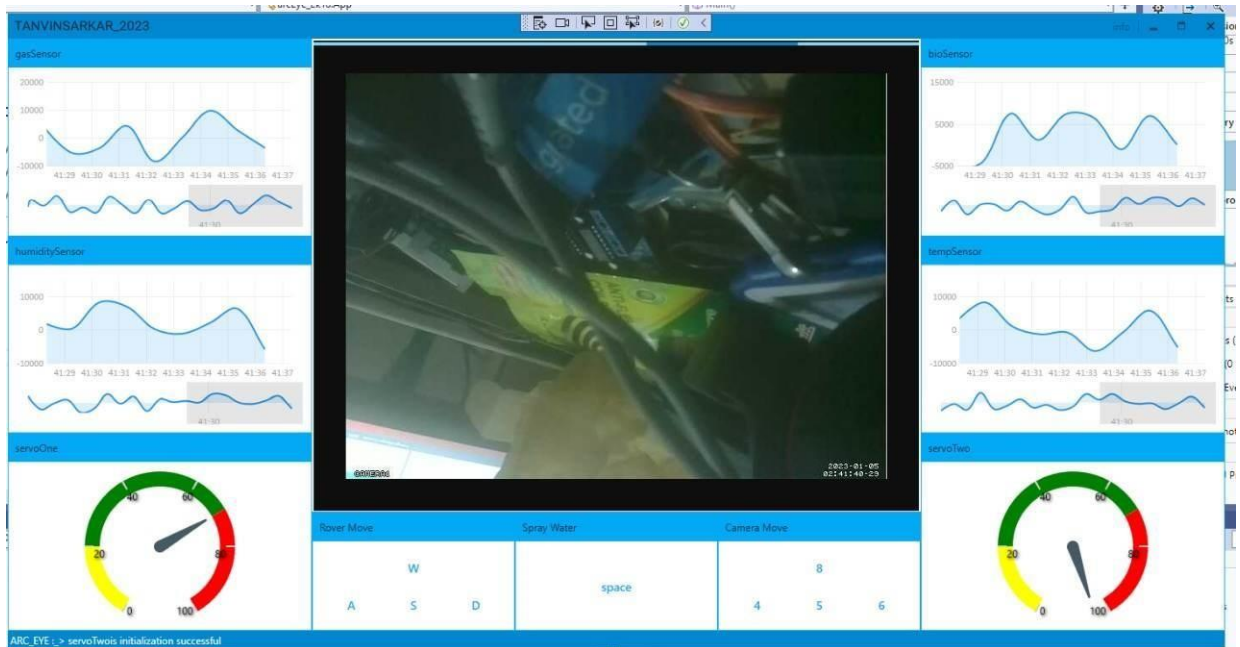

**Figure 5.2:** Result analysis of hardware model

A firefighting robot with a water tank and pistol can be operated wirelessly from anywhere thanks to this cutting-edge device called the Fire Fighter Robotic Vehicle with Night Vision Camera. The system's robotic vehicle and water pump are controlled by means of an RF remote and an RF receives based microcontroller circuit. The receiver circuit listens for radio frequency signals in response to user commands sent via radio frequency (RF)-based remote transfer. At this point, the data commands are decoded by the receiver circuit. To the microcontroller it is then sent. Following this, the microcontroller issues commands to the vehicle's motors, it propel it in the specified directions. Furthermore, it uses user input to power the water pump and control the spray's angle. In this way, the user can control the robot and extinguish the fire without having to risk injury. The robot head is equipped with a wireless camera that can capture images in the dark. The robot's body may be pointed in any direction with the aid of its night vision camera. That's because the footage from your wireless camera may be seen on your computer for future reference, no matter what region you happen to be monitoring at the time. The robot can function up to 8 meters away from the controller. The robot's water tank allows the device to put out fires from a safe distance.

## Comparison of Results

The primary goal of this robot is to be able to automatically detect fires, travel towards them, and put them out from a safe distance by utilizing a water spray. The Arduino microcontroller is responsible for

all of the robot's motion and behavior. This robot can detect fires and put them out by traveling in all directions like a car. The purpose of this project is to create a firefighting robot controlled by Bluetooth that can be programmed in Arduino. In the publication, the authors present a prototype of a mobile firefighting robot that uses water to extinguish blazes. Robot will monitor the work done by arbitrary developments; it as an alternative media used by people, especially the firefighter, to battle fire. This robot is implemented with high fire temperature to assess the affectability of distinguishing then cancels the fire by using water instrument. Water can be dispensed from the vehicle's tank through a siphon. A smoke detector is used to identify the presence of fire. An analog output is really generated by a circuit connected to a smoke sensor in the event of a fire. This analog output is hardwired to an Arduino I/O pin to serve as an interrupt signal. Interrupt service functions run motor-driven programs, or parts of them, when sensor outputs are high (interrupt signal to raspberry pi). A water sprinkler system is coupled to the shaft of the dc motor, and activated whenever the sensor detects fire.

## **Summary**

The purpose of this study is to outline the steps necessary to build an Arduino-based robot firefighter with the capability of using Bluetooth to automatically put out fires. The firefighting robot's primary function is to survey the area, pinpoint the fire's location, and identify its characteristics from a protected distance. It's simple to use with Bluetooth-enabled gadgets, simplifying its use for the user. The wide range of possible applications means it can be used anywhere from homes to laboratories to parking lots to grocery stores. Given the low price, they are accessible to everyone. It detects fires with a high degree of precision. The firefighting robot has these features, therefore it's an obvious pick.



## Chapter 6

# CONCLUSION

### Summary of Findings

Fire plays an essential role in human existence, yet it also poses risks. A fire is a catastrophic event that can result in the loss of life, damage to property, and permanent impairment of the affected casualty. While firefighters are often responsible for extinguishing fires, they face increased hazard when doing so, especially in high-risk environments like nuclear power plants, oil refineries, and gas storage tanks. However, when a fire occurs in a small, enclosed space, they must overcome additional challenges in order to extinguish the flames and save the victim, such as examining the remains of nearby buildings and obstacles.[33] That's why this study details recent developments in fire suppression. A robot with in-built fire suppression devices would eliminate the need for human firefighters. This Fighting flames With the help of a Bluetooth model, we're able to direct the robot's movements and determine where the fire is located. The robot is also equipped with a smoke detector and a thermometer that can detect the ambient temperature. This article is an attempt to provide a technical solution to the aforementioned problem.

### Novelty of the work

An autonomous robotic system for fighting fires has been developed, complete with sensors for fire detection and alarm, an avoidance behavior mechanism, and the capacity to send text messages. The fire and smoke were effectively put out. Installing an ultrasonic sensor in theMicrocontroller effectively identified robotic system, which expressed itself in the system's avoidance of the barrier. Once fire and smoke were detected, the alarm went off as well as the SMS messaging capabilities.[34] A brief text message alerting the owner that a fire has been discovered was sent to their mobile device. Simply put, this data points to the fact that the artificial autonomous robotic system designed to combat fires was doing so. Since all of the study's goals have been met, it can be stated that the proposed system is trustworthy and reasonably priced and should be used in fire fighting operations to reduce casualties and damage to buildings and other infrastructure.

## **Cultural and Societal Factors and Impacts**

In the most recent phase of industrialization, robotics technology has grown increasingly commonplace. The ability of artificially intelligent robots to interact with humans with little or no human intervention is crucial. To a human, interacting with a robot these days is no different than interacting with any other piece of technology. devices of modern technology[34]. Artificially intelligent robots and interactive interactions can accomplish tasks with little to no human oversight, and this is far more significant. Reports indicate that the calamity caused by the fire will nearly completely destroy everything. Almost anything that a flame touches will be consumed by it. A little spark may ignite into a devastating blaze in just a minute. In a matter of minutes, a building can fill with dense black smoke and be completely consumed in flames. Within a few short seconds, everything will be reduced to ashes. Good procedures will be put into place to lessen the damage fires can do in order to forestall any potential fire disasters. Large-scale devastation can be drastically mitigated if fires are discovered and put out as soon as possible. Today, a wide variety of fire extinguishing systems exist, each employing a somewhat different set of principles and procedures. (1) Non-solid extinguishing products were covered by patents that could be purchased for use in fire suppression. It is common knowledge that all communities have fire departments to deal with the occasional unintentional fire. It is expected that all fire departments across the country would continue to rely on the tried-and-true method of extinguishing fires by adding additional firemen to the mix.

## **Limitations of the Work**

The overarching goal of this research was to lessen the severity of potential fire disasters by introducing a new technology fire fighting robot. The topic this year, "Utilizing Science Innovation, Promoting Disaster Risk Reduction," sparked the idea for the study. Three months ago, the study was done with the hope of incorporating a novel approach to lowering danger associated with implementing this microcontroller-based system. The circuit design of the robotic firefighting system was designed to assure its operation by including sensitive flame sensors, an avoidance mechanism, an alert, and the capacity to send text messages.[35]

- When it comes to the introduction of robotic automation, one of the main concerns is affects of equipments. There is concern that humans will become obsolete if robots can perform the same

tasks at a higher rate of efficiency. These concerns are rational, but they are not grounded in reality.

- The problem is further complicated by the advent of automation; robots need to be programmed, and their operation necessitates expertise.
- Problem is further complicated by the advent of automation; robots need to be programmed, and their operation necessitates expertise.

## **Future Scopes**

New technologies, such as drones, will become increasingly important to fire departments. The combination of their autonomous capabilities, light weight, and long range control systems makes them ideal for scanning hostile terrain and hazardous situations like forest fires. They can give fire departments up-to-the-minute information on the status of dangerous blazes, improving the effectiveness of tactical unit deployments. Drones equipped with thermal imaging cameras are already being used by the West Midlands Fire Service to increase fire crew situational awareness, enhance fire crew safety, and reduce response times. In addition to being utilized for fire detection, I foresee drones being employed in fire prevention and suppression. Water and fire suppression drops from several drones are already being coordinated by the Wind racers' SWARM project as part of the UKRI's Future Flight Challenge. Skyscraper fires may also benefit from the usage of drones, which could allow firefighters to reach floors previously inaccessible.

## **Social, Economic, Cultural and Environmental Aspects**

### **Sustainability**

Every fire in a structure or factory also hurts the environment and poses a risk to human life and health, not to mention the financial losses. For this reason alone, fire alarm systems provide an essential contribution to sustainability. Bosch systems safeguard the environment and its resources in other ways as well, such as through resilience, adaptability, and remote monitoring. Air pollution is usually exacerbated by fires. Particulate matter, smoke, and soot particles are all examples of emissions. When materials burn, they generate pollutants that are exceedingly damaging to the environment and health, heightening the threat. With its high dependability and quick response time, Bosch fire alarm systems play a crucial role

in avoiding the spread of fires in buildings and facilities across the world. A video-based fire detection technology has extra benefits in harsh conditions like those found in industrial settings or the trash and recycling industry.[37] The unexpected combination of chemicals and substances in these sites and the circumstances and operational activities make them hazardous places with ongoing high fire hazards. Small button batteries, spray cans, leftovers of cosmetic or cleaning products, cigarette lighters or damaged electronics constitute a deadly mix. After ignition, the waste and the surrounding dry, dusty conditions are likely to provide a steady supply of fuel for the fire. Within minutes, a fire can spread over a large area, producing hazardous smoke from burning chemicals or materials that poses a threat to both human life and the environment.

### **Economic and Cultural Factors**

Extreme weather events, technological mishaps, climate change, and other asymmetric non-classical activities of unknown nature have recently had widespread impacts on people's daily lives and on society as a whole. These are all reasons to call 911 immediately. Scale is an issue when it comes to the casualty and property damage output of some types of disaster generators. In today's world, stability, security, and policy and strategy development at all levels and in all fields must include prevention and emergency management. The main protagonist is the one who must go to the scene of the emergency, perform analysis, and make crucial life-or-death decisions. Unfortunately, it still has limitations despite how well planned it is.

Cooperative human and mechanical intelligence is the key to resolving this issue. Because of this, it is imperative to build a technical link between humans, robots, and crisis intervention strategies. Therefore, in recent years, researchers have focused primarily on satisfying the needs of replacement personnel for the execution of high-risk missions in challenging environments, with the help of controlled, accelerated progress in the fields of mechatronics, optoelectronics, electronics, computing power, and the market providing the specialized technologies needed to accomplish this. The creation of families of prevention- and intervention-focused robots that can move in high-risk regions before an incident becomes out of hand, whether to save people or collect data that will help humans respond more effectively, is one option[38].

### **Conclusion**

Robotic devices are already prevalent in many civilian and military contexts thanks to the significant progress made in robotics research and development over the past decade. There are so many distinct types of robots, androids, static robots, mobile telemobile robots, autonomous robots, and semi-

autonomous robots that it would be practically impossible to include them all here. Crucial to the global effort to combat climate change, studies like the ones you highlighted are. global initiative to mitigate climate change and lessen its damaging impacts, with the goals of meeting present and future needs without jeopardizing future generations' access to a habitable planet.

## REFERENCES

- [1] Kumar, Ajitesh, and Mona Kumari. "Design and implementation of AI Based Robotic Car for Surveillance and transportation." *IOP Conference Series: Materials Science and Engineering*. Vol. 1116. No. 1. IOP Publishing, 2021.
- [2] Vanitha, M., M. Selvalakshmi, and R. Selvarasu. "Monitoring and controlling of mobile robot via internet through raspberry Pi board." *2016 Second International Conference on Science Technology Engineering and Management (ICONSTEM)*. IEEE, 2016.
- [3] Iqbal, M. J., Iqbal, M. M., Ahmad, I., Alassafi, M. O., Alfakeeh, A. S., & Alhomoud, A. (2021). Real-Time Surveillance Using Deep Learning. *Security and Communication Networks*, 2021.
- [4] Dharaskar, Mayank, et al. "IOT Based Surveillance Robotic Car Using Raspberry Pi." *International Research Journal of Engineering and Technology (IRJET)* 5.3 (2018): 442-425.
- [5] Sirasanagandla, Sushma, Mounisha Pachipulusu, and Ramesh Jayaraman. "Development of surveillance robot to monitor the work performance in hazardous area." *2020 International Conference on Communication and Signal Processing (ICCSP)*. IEEE, 2020.
- [6] Fang, Bin, et al. "A robotic hand-arm teleoperation system using human arm/hand with a novel data glove." *2015 IEEE International Conference on Robotics and Biomimetics (ROBIO)*. IEEE, 2015.
- [7] Chatel, Sylvain, and Cedric Pradalier. "CS8903 Special Problem: Mesh Networks for robotic teleoperation-State of the Art and Implementation for Robotics." (2016).
- [8] Hiyama, Atsushi, et al. "Facilitating remote communication between senior communities with telepresence robots." *International Conference on Human Aspects of IT for the Aged Population*. Springer, Cham, 2017..
- [9] Bokade, Ashish U., and V. R. Ratnaparkhe. "Video surveillance robot control using smartphone and Raspberry pi." *2016 International Conference on Communication and Signal Processing (ICCSP)*. IEEE, 2016.
- [10] Sebastian, Novandri, and Erny Listijorini. "Designing and Prototyping Surveillance Robot with Self-Protection using Nail Gun." *Applied Mechanics and Materials*. Vol. 493. Trans Tech Publications Ltd, 2014.
- [11] Metev, Simeon M., and Vadim P. Veiko. *Laser-assisted microtechnology*. Vol. 19. Springer Science & Business Media, 2013.
- [12] Breckling, Jens. *The analysis of directional time series: applications to wind speed and direction*. Vol. 61. Springer Science & Business Media, 2012.

- [13] Zhang, Shengdong, et al. "A novel ultrathin elevated channel low-temperature poly-Si TFT." *IEEE Electron Device Letters* 20.11 (1999): 569-571.
- [14] Wegmuller, M., et al. "High resolution fiber distributed measurements with coherent OFDR." *Proc. ECOC'00*. Vol. 11. No. 4. 2000.
- [15] Sorace, Ronald E., Victor S. Reinhardt, and Steven A. Vaughn. "High-speed digital-to-RF-converter." U.S. Patent No. 5,668,842. 16 Sep. 1997.
- [16] (2002) The IEEE website. [Online]. [Cited: December 1, 2008.] Available: <http://www.ieee.org/>
- [17] M. Shell. (2002) IEEEtran homepage on CTAN. [Online]. [Cited: December 1, 2008.] Available: <http://www.ctan.org/tex-archive/macros/latex/contrib/supported/IEEEtran/>
- [18] FLEXChip Signal Processor (MC68175/D), Motorola, 1996.
- [19] "PDCA12-70 data sheet," Opto Speed SA, Mezzovico, Switzerland.
- [20] Karnik, Aditya. "Performance of TCP congestion control with rate feedback: TCP/ABR and rate adaptive TCP/IP." *M. Eng. thesis, Indian Institute of Science, Bangalore, India* 1 (1999).
- [21] Padhye, Jitendra, Victor Firoiu, and Don Towsley. "A Stochastic Model of TCP Reno Congestion Avoidance and Control CMPSCI Technical Report 99-02."
- [22] IEEE Computer Society LAN MAN Standards Committee. "Wireless LAN medium access control (MAC) and physical layer (PHY) specifications." *ANSI/IEEE Std. 802.11-1999* (1999).
- [23] Yaman, F., Q. Lin, and Govind P. Agrawal. "Fiber-optic parametric amplifiers for lightwave systems." *Guided Wave Optical Components and Devices* (2005).
- [24] Sullivan, Andrew, Elaine Baker, and Tiina Kurvits. "Spreading Like Wildfire: The Rising Threat of Extraordinary Landscape Fires." (2022).
- [25] Haksar, Ravi N., and Mac Schwager. "Distributed deep reinforcement learning for fighting forest fires with a network of aerial robots." *2018 IEEE/RSJ International Conference on Intelligent Robots and Systems (IROS)*. IEEE, 2018.

- [26] Perumal, Kalaivani AP, Musab AM Ali, and Zainab Hussein Yahya. "Fire fighter robot with night vision camera." *2019 IEEE 15th International Colloquium on Signal Processing & Its Applications (CSPA)*. IEEE, 2019.
- [27] HAN NI ZAW and TIN TIN HLA. "Design and Implementation of Automatic Obstacle Avoidance Car Control System", *1st International Conference on Engineering, Communication and Computer Sciences (ICECCS 2018)*, 2018.
- [28] Aliff, Mohd, et al. "Development of fire fighting robot (QROB)." *International Journal of Advanced Computer Science and Applications* 10.1 (2019).
- [29] Rahman, Arifur. *Assignment on Temperature Sensors*. Technical Report, 2018, DOI: 10.13140/RG.2.2.16747.23844, 2018.
- [30] Bhargava, Ankur, and Anjani Kumar. "Arduino controlled robotic arm." *2017 International conference of Electronics, Communication and Aerospace Technology (ICECA)*. Vol. 2. IEEE, 2017.
- [31] Nagesh, M. S., T. V. Deepika, and M. Shivakumar Stafford Michahial. "Fire Extinguishing Robot." *International Journal of Advanced Research in Computer and Communication Engineering* 5.12 (2016).
- [32] Rakib, Tawfiqur, and MA Rashid Sarkar. "Design and fabrication of an autonomous fire fighting robot with multisensor fire detection using PID controller." *2016 5th International Conference on Informatics, Electronics and Vision (ICIEV)*. IEEE, 2016.
- [33] Engin, Mustafa. "Embedded and real time system design: A case study fire fighting robot." *2016 5th Mediterranean Conference on Embedded Computing (MECO)*. IEEE, 2016.
- [34] Lee, Chyi-Shyong, et al. "A project-based laboratory for learning embedded system design with industry support." *IEEE Transactions on Education* 53.2 (2009): 173-181.
- [35] Seiler, Sven, Raivo Sell, and Dennis Ptasik. "Embedded System and Robotic Education in a Blended Learning Environment Utilizing Remote and Virtual Labs in the Cloud, Accompanied by a Robotic HomeLab Kit?" *International Journal of Emerging Technologies in Learning (iJET)* 7.4 (2012): 26-33.
- [36] Maddukuri, Satya Veera Pavan Kumar, et al. "A low cost sensor based autonomous and semi-autonomous fire-fighting squad robot." *2016 Sixth International Symposium on Embedded Computing and System Design (ISED)*. IEEE, 2016.
- [37] Priyanka, S. Sakthi, et al. "Android Controlled Fire Fighting Robot." *International Journal of Innovative Science Engg. and Technology* 3 (2017).
- [38] Development & Applications of Automatic Fire fighting robot-International Journal of Advanced Research in Computer Engineering & Technology- Paul ESandin, vol.2, issue14, 2013.



- [39] International Journal of Recent Research in Mathematics Computer science and Technology-Abilash, Dhumathar, Sumit, Bhiogade, vol.2, Issue., April 2015
- [40] Roy, Sudipta, et al. "International journal of advanced research in computer science and software engineering." *International Journal* 3.6 (2013).

## Appendix A

### Datasheet of the ICs used

```
#include <Servo.h>
```

```
Servo myservo;
```

```
int pos = 0;
```

```
boolean fire = false;
```

```
/*-----defining Inputs-----*/
```

```
#define Left_S 9 // left sensor
```

```
#define Right_S 10 // right sensor
```

```
#define Forward_S 8 //forward sensor
```

```
/*-----defining Outputs -----*/
```

```
#define LM1 2 // left motor
```

```
#define LM2 3 // left motor
```

```
#define RM1 4 // right motor
```

```
#define RM2 5 // right motor
```

```
#define pump 6
```

```
void setup()
```

```
{
```

```
pinMode(Left_S, INPUT);
```

```
pinMode(Right_S, INPUT);
```

```
pinMode(Forward_S, INPUT);
```

```
pinMode(LM1, OUTPUT);
```

```
pinMode(LM2, OUTPUT);
```

```
pinMode(RM1, OUTPUT);
```

```
pinMode(RM2, OUTPUT);
```

```
pinMode(pump, OUTPUT);
```

```
myservo.attach(11);
```

```
myservo.write(90);
```

```
}
```

```
void put_off_fire()
```

```
{
```

**delay (500);**

**digitalWrite(LM1, HIGH);**

**digitalWrite(LM2, HIGH);**

**digitalWrite(RM1, HIGH);**

**digitalWrite(RM2, HIGH);**

**digitalWrite(pump, HIGH); delay(500);**

**for (pos = 50; pos <= 130; pos += 1) {**

**myservo.write(pos);**

**delay(10);**

**}**

**for (pos = 130; pos >= 50; pos -= 1) {**

```
myservo.write(pos);
```

```
delay(10);
```

```
}
```

```
digitalWrite(pump,LOW);
```

```
myservo.write(90);
```

```
fire=false;
```

```
}
```

```
void loop()
```

```
{
```

```
myservo.write(90); //Sweep_Servo();
```

```
if (digitalRead(Left_S) ==1 && digitalRead(Right_S)==1 &&
```

```
digitalRead(Forward_S) ==1) //If Fire not detected all sensors are zero
```

```
{  
  
//Do not move the robot  
  
digitalWrite(LM1, HIGH);  
digitalWrite(LM2, HIGH);  
digitalWrite(RM1, HIGH);  
digitalWrite(RM2, HIGH);  
  
}  
  
else if (digitalRead(Forward_S) ==0) //If Fire is straight ahead  
  
{  
  
//Move the robot forward  
  
digitalWrite(LM1, HIGH);  
digitalWrite(LM2, LOW);  
digitalWrite(RM1, HIGH);
```

```
digitalWrite(RM2, LOW);
```

```
fire = true;
```

```
}
```

```
else if (digitalRead(Left_S) ==0) //If Fire is to the left
```

```
{
```

```
//Move the robot left
```

```
digitalWrite(LM1, HIGH);
```

```
digitalWrite(LM2, LOW);
```

```
digitalWrite(RM1, HIGH);
```

```
digitalWrite(RM2, HIGH);
```

```
}
```

```
else if (digitalRead(Right_S) ==0) //If Fire is to the right
```

```
{
```

```
//Move the robot right
```

```
digitalWrite(LM1, HIGH);
```

```
digitalWrite(LM2, HIGH);
```

```
digitalWrite(RM1, HIGH);
```

```
digitalWrite(RM2, LOW);
```

```
}
```

```
delay(300); //Slow down the speed of robot
```

```
while (fire == true)
```

```
{
```

```
put_off_fire();
```

```
}
```



}

## Appendix B

### iThenticate Plagiarism Report

#### IoT Based Robotic Car Design

---

ORIGINALITY REPORT

---

**19%**

SIMILARITY INDEX

---

PRIMARY SOURCES

---

1	<a href="http://mafiadoc.com">mafiadoc.com</a> Internet	256 words — 2%
2	<a href="http://dspace.aiub.edu">dspace.aiub.edu</a> Internet	222 words — 2%
3	<a href="http://www.coursehero.com">www.coursehero.com</a> Internet	142 words — 1%
4	<a href="http://www.irjmets.com">www.irjmets.com</a> Internet	137 words — 1%
5	<a href="http://es.scribd.com">es.scribd.com</a> Internet	97 words — 1%
6	<a href="http://dokumen.pub">dokumen.pub</a> Internet	71 words — 1%
7	<a href="http://www.ijste.org">www.ijste.org</a> Internet	67 words — 1%
8	Nuță, Ionel, Octavian Orban, and Lucian Grigore. "Development and Improvement of Technology in Emergency Response", <i>Procedia Economics and Finance</i> , 2015. Crossref	59 words — < 1%
9	<a href="http://www.ijert.org">www.ijert.org</a> Internet	

Vision Camera", 2019 IEEE 15th International Colloquium on  
Signal Processing & Its Applications (CSPA), 2019

Crossref

- |    |  |                |
|----|--|----------------|
| 69 | <a href="http://dspace.nwu.ac.za">dspace.nwu.ac.za</a><br>Internet   | 8 words — < 1% |
| 70 | <a href="http://ijesmr.com">ijesmr.com</a><br>Internet   | 8 words — < 1% |
| 71 | <a href="http://serisc.org">serisc.org</a><br>Internet   | 8 words — < 1% |
| 72 | <a href="http://upcommons.upc.edu">upcommons.upc.edu</a><br>Internet   | 8 words — < 1% |
| 73 | <a href="http://www.gat.ac.in">www.gat.ac.in</a><br>Internet   | 8 words — < 1% |
| 74 | <a href="http://www.ijarse.com">www.ijarse.com</a><br>Internet   | 8 words — < 1% |
| 75 | "Proceedings of the International Conference on Ubiquitous Computing & Ambient Intelligence (UCAI 2022)", Springer Science and Business Media LLC, 2023<br>Crossref  | 6 words — < 1% |
| 76 | Khondker Zakir Ahmed, Syed Mustafa Khelat Bari, Didar Islam, A. B. M. Harun-ur Rashid. "Design and implementation of PFM mode high efficiency boost regulator", Analog Integrated Circuits and Signal Processing, 2011<br>Crossref | 6 words — < 1% |
| 77 | Novandri Sebastian, Erwin, Erny Listijorini, Dwinanto. "Designing and Prototyping Surveillance Robot with Self-Protection Using Nail Gun", Applied Mechanics and Materials, 2014<br>Crossref                                       | 6 words — < 1% |

Surveillance Bot for Remote Observation During Pandemics",  
2020 5th International Conference on Communication and  
Electronics Systems (ICCES), 2020

Crossref

- 
- 61** Joyal Raju, S Sheik Mohammed, Johaan Varkey Paul, Georgy Abel John, Dinanath S. Nair. "Development and implementation of arduino microcontroller based dual mode fire extinguishing robot", 2017 IEEE International Conference on Intelligent Techniques in Control, Optimization and Signal Processing (INCOS), 2017  
9 words — < 1%  
Crossref
- 
- 62** Mohd Aliff, Nor Samsiah, MI Yusof, Azavitra Zainal. "Development of Fire Fighting Robot (QRob)", International Journal of Advanced Computer Science and Applications, 2019  
9 words — < 1%  
Crossref
- 
- 63** d-scholarship.pitt.edu  
Internet  
9 words — < 1%
- 
- 64** eprints.itn.ac.id  
Internet  
9 words — < 1%
- 
- 65** ijsrset.com  
Internet  
9 words — < 1%
- 
- 66** worldwidescience.org  
Internet  
9 words — < 1%
- 
- 67** www.majju.pk  
Internet  
9 words — < 1%
- 
- 68** Kalaivani AP Perumal, Musab A. M. Ali, Zainab Hussein Yahya. "Fire Fighter Robot with Night

49	"Committees", 14th International Conference on Computer and Information Technology (ICCIT 2011), 12/2011 <small>Crossref</small>	13 words — < 1%
50	etd.aau.edu.et <small>Internet</small>	12 words — < 1%
51	manuals.plus <small>Internet</small>	12 words — < 1%
52	docshare.tips <small>Internet</small>	11 words — < 1%
53	journals.plos.org <small>Internet</small>	11 words — < 1%
54	research.unilus.ac.zm <small>Internet</small>	11 words — < 1%
55	core.ac.uk <small>Internet</small>	10 words — < 1%
56	ijircce.com <small>Internet</small>	10 words — < 1%
57	muhendislik.halic.edu.tr <small>Internet</small>	10 words — < 1%
58	pic-microcontroller.com <small>Internet</small>	10 words — < 1%
59	www.ijarbest.com <small>Internet</small>	10 words — < 1%
60	Asha Rashmi Nayak, Saishree CS Ayyar, O. Aiswarya, Mahitha CH, N. Mohankumar. "Security	9 words — < 1%

37	<a href="http://coek.info">coek.info</a> Internet	18 words — < 1%
38	<a href="http://ctan.math.washington.edu">ctan.math.washington.edu</a> Internet	18 words — < 1%
39	<a href="http://www.ece.ucf.edu">www.ece.ucf.edu</a> Internet	18 words — < 1%
40	<a href="http://www.bipcons.ce.tuiasi.ro">www.bipcons.ce.tuiasi.ro</a> Internet	17 words — < 1%
41	<a href="http://www.rcciit.org">www.rcciit.org</a> Internet	17 words — < 1%
42	<a href="http://www.scientific.net">www.scientific.net</a> Internet	17 words — < 1%
43	<a href="http://easychair.org">easychair.org</a> Internet	16 words — < 1%
44	<a href="http://vbook.pub">vbook.pub</a> Internet	16 words — < 1%
45	<a href="http://connections-qj.org">connections-qj.org</a> Internet	15 words — < 1%
46	<a href="http://vfast.org">vfast.org</a> Internet	15 words — < 1%
47	<a href="http://dergipark.org.tr">dergipark.org.tr</a> Internet	14 words — < 1%
48	<a href="http://www.slideshare.net">www.slideshare.net</a> Internet	14 words — < 1%

27	<a href="http://pcl.cs.ucla.edu">pcl.cs.ucla.edu</a> Internet	24 words — < 1%
28	<a href="mailto:mail.ijaers.com">mail.ijaers.com</a> Internet	23 words — < 1%
29	V.G. Rajendran, S. Jayalalitha, S. Radhakrishnan, S. Arunbhaarat. "Webpage controlled surveillance bot using Raspberry Pi", 2020 Fourth International Conference on I-SMAC (IoT in Social, Mobile, Analytics and Cloud) (I-SMAC), 2020 Crossref	22 words — < 1%
30	<a href="http://avesis.ege.edu.tr">avesis.ege.edu.tr</a> Internet	22 words — < 1%
31	<a href="http://moh.circololegambienteamalfi.it">moh.circololegambienteamalfi.it</a> Internet	21 words — < 1%
32	Md. Akram Hossain, Fatematuz Jahura, Md. Ashikur Rahman, Tarem Ahmed. "IoT-based Drunk Driving Detection and Engine Locking System with Real-Time Location in App", TENCON 2022 - 2022 IEEE Region 10 Conference (TENCON), 2022 Crossref	20 words — < 1%
33	<a href="http://eudl.eu">eudl.eu</a> Internet	20 words — < 1%
34	<a href="http://pdxscholar.library.pdx.edu">pdxscholar.library.pdx.edu</a> Internet	20 words — < 1%
35	<a href="http://cdn.iiyama.com">cdn.iiyama.com</a> Internet	19 words — < 1%
36	<a href="http://1library.net">1library.net</a> Internet	18 words — < 1%

- 
- 20 B. Doraswamy, K. Lokesh Krishna, M. N. Giri Prasad. "Machine Learning Strategies for the Implementation of a Surveillance Drone", 2021 IEEE 4th International Conference on Electronics and Communication Engineering (ICECE), 2021  
30 words — < 1%  
Crossref
- 
- 21 Rui Li, Hongyu Wang, Zhenyu Liu. "Survey on Mapping Human Hand Motion to Robotic Hands for Teleoperation", IEEE Transactions on Circuits and Systems for Video Technology, 2021  
26 words — < 1%  
Crossref
- 
- 22 ccets.cgg.gov.in  
26 words — < 1%  
Internet
- 
- 23 eprints.soton.ac.uk  
26 words — < 1%  
Internet
- 
- 24 helixscientific.pub  
26 words — < 1%  
Internet
- 
- 25 Deyby Huamanchahua, Danitza Yalli-Villa, Angel Bello-Merlo, Jalber Macuri-Vasquez. "Ground Robots for Inspection and Monitoring: A State-of-the-Art Review", 2021 IEEE 12th Annual Ubiquitous Computing, Electronics & Mobile Communication Conference (UEMCON), 2021  
25 words — < 1%  
Crossref
- 
- 26 Lev A. Kleiman, Vladimir I. Freyman. "The Method of Dynamic Distribution of the Diagnostic Load Between Information and Control Systems Elements", 2021 IEEE Conference of Russian Young Researchers in Electrical and Electronic Engineering (ElConRus), 2021  
25 words — < 1%  
Crossref
-



53 words — < 1%

10 Md Abdullah Al Rakib, Md Moklesur Rahman, Md Shamsul Alam Anik, Fayez Ahmed Jahangir Masud et al. "Fire Detection and Water Discharge Activity for Fire Fighting Robots using IoT", European Journal of Engineering and Technology Research, 2022  
Crossref

11 www.jseis.org  
Internet 46 words — < 1%

12 online-journals.org  
Internet 38 words — < 1%

13 unsworks.unsw.edu.au  
Internet 38 words — < 1%

14 www.researchgate.net  
Internet 36 words — < 1%

15 fr.slideshare.net  
Internet 35 words — < 1%

16 www.xajzkjdx.cn  
Internet 33 words — < 1%

17 jnte.ft.unand.ac.id  
Internet 32 words — < 1%

18 tojqi.net  
Internet 32 words — < 1%

19 www.kcca.go.ug  
Internet 31 words — < 1%

