

American International University- Bangladesh

Department of Computer Engineering

COE 3201: Data Communication Laboratory

Title: Study of Amplitude Modulation and Demodulation using Simulink

Abstract:

This experiment is designed to-

- 1.To understand the use of Simulink for AM modulation.
- 2.To develop understanding of AM demodulation.

Introduction:

Amplitude modulation (AM) is a one of the conventional technique used to transmit message signals using a carrier wave. The amplitude or strength of the high frequency carrier wave is modified in accordance with amplitude of the message signal.

- Carrier signal (S_c) = $A_c \sin(2\pi f_c t)$
- Message signal (S_m) = $A_m \sin(2\pi f_m t)$ # f_m must be smaller than f_c

When carrier amplitude is altered with respect to message signal,

- Modulated Signal = $(A_c + A_m \sin(2\pi f_m t)) * \sin(2\pi f_c t)$

In terms of modulation index ($m = A_m/A_c$) the equation becomes

- **Modulated signal = $(1 + m \sin(2\pi f_m t)) * A_c \sin(2\pi f_c t)$**

Where,

- A_c = Carrier signal amplitude
- A_m = Message signal amplitude
- f_c = Carrier frequency
- f_m = Message frequency

Generating AM in Simulink

For generating AM we just have to implement the equation of AM in block level.

Blocks Required

Analyzing the equation we need,

1. Carrier Signal Source
2. Message Signal Source
3. Blocks for viewing the signals – Scope
4. Product Block
5. Summer Block
6. Constant Block

We can find these blocks in the following locations of Simulink Library...

Carrier, Message, Constant blocks

- Simulink → Sources → Sine wave
- Simulink → Sources → Constant

View Block

- Simulink → Sink → Scope

Product and Summer Block

- Simulink → Math Operations → Product
- Simulink → Math Operations → Summer

Block Diagram

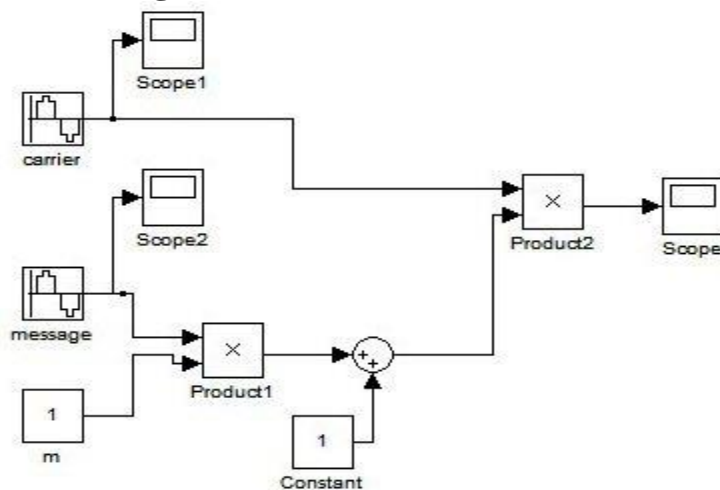

AM Generation using Simulink – Block Diagram

Block parameters can be changed by selecting the block and parameter:

- Carrier Signal frequency = $2\pi \cdot 25$ and sampling time = $1/5000$
- Message Signal frequency = 2π and sampling time = $1/5000$
- Amplitudes of both signals are 1

Output Waveforms

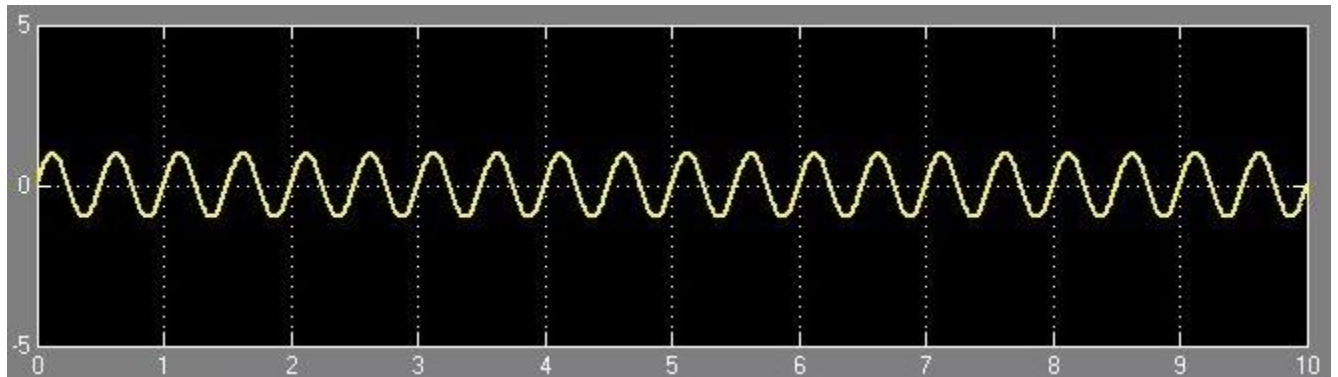

AM Generation using Simulink – Message Signal

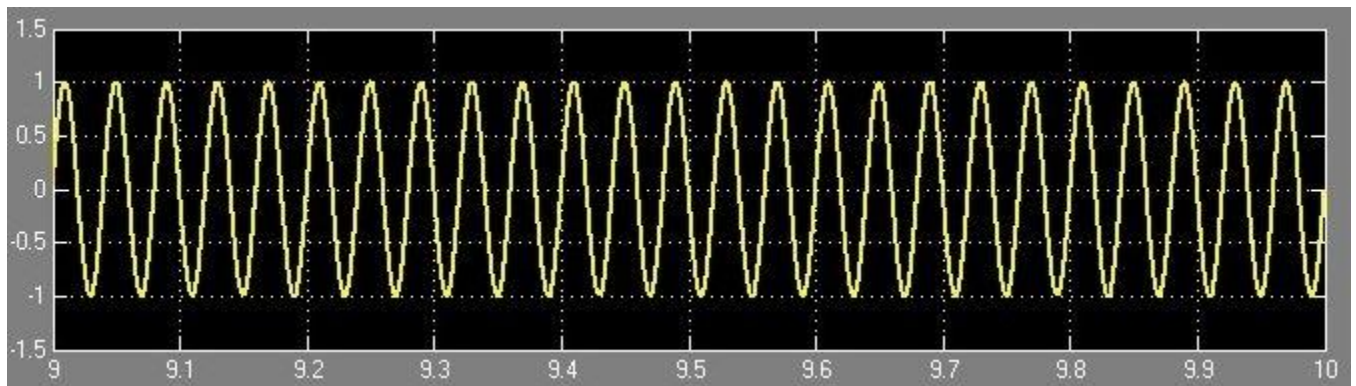

AM Generation using Simulink – Carrier

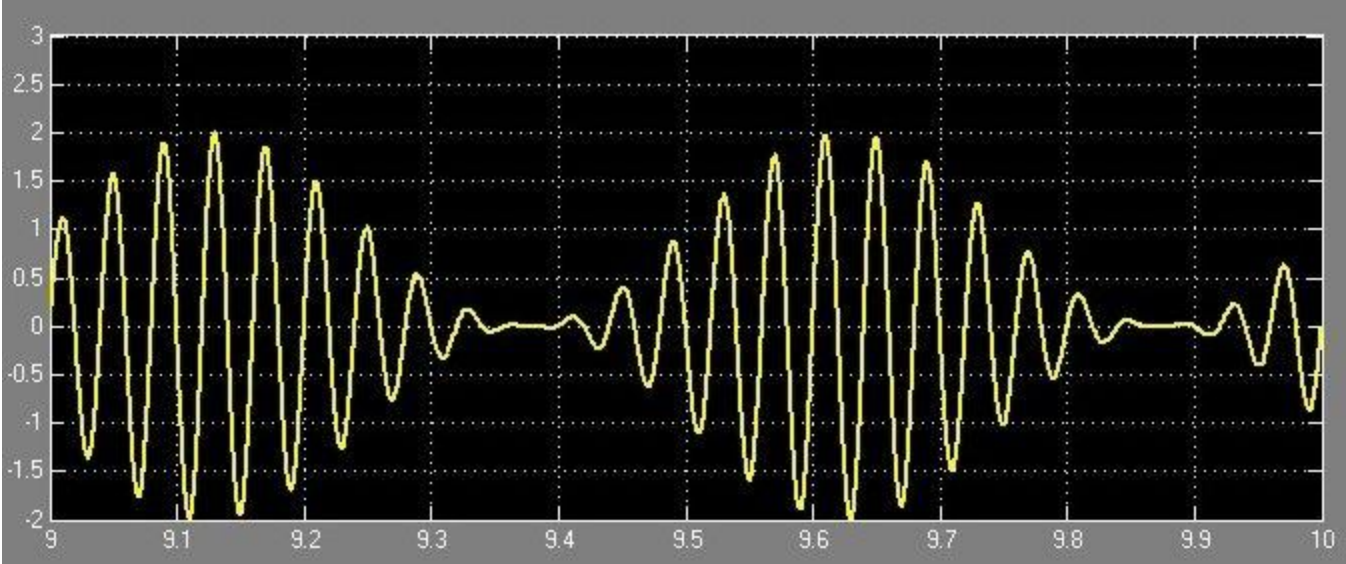

AM Generation using Simulink – Modulated Signal

Performance Task:

- 1. Perform demodulation according to the following diagram (general)

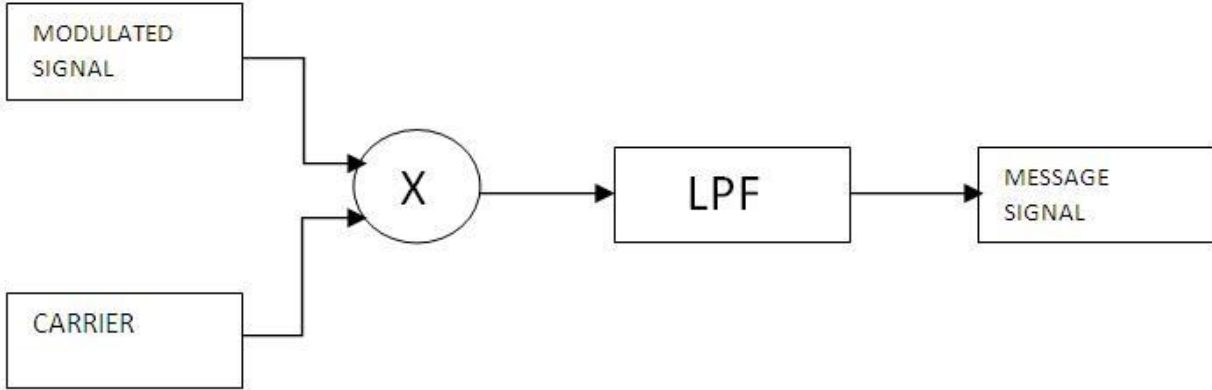

Implement the following demodulation in Simulink to retrieve the original signal:

